



**ENGINEERS REPORT FOR
THE IMPROVEMENT OF THE
SOUTH CYRVILLE
MUNICIPAL DRAIN
Located at 1410 Triolet Street,
Ottawa, Ontario**

Prepared for:
The City of Ottawa
100 Constellation Crescent
Ottawa, ON K2G 6J8

Prepared by:
Stantec Consulting Ltd.
1505 Laperriere Avenue
Ottawa, ON K1Z 7T1

February 2012

Table of Contents

1.0 INTRODUCTION	1.1
2.0 HISTORY	2.1
3.0 WATERSHED CHARACTERISTICS	3.1
3.1 DRAINAGE AREA	3.1
3.2 ENVIRONMENTAL	3.2
3.3 LEGAL AND SUFFICIENT OUTLET	3.2

4.0 AREA REQUIRING DRAINAGE	4.1
4.1 EXISTING DRAIN LOCATION.....	4.1

5.0 IMPROVEMENTS AND RECOMMENDATIONS	5.1
5.1 PROPOSED DRAIN LOCATION	5.1

6.0 DESIGN RECOMMENDATIONS.....	6.1
6.1 CONSTRUCTION PROVISIONS-GENERAL	6.1
6.1.1 Design.....	6.1
6.1.2 Channel Section.....	6.2
6.1.3 Alignment.....	6.2
6.1.4 Private Crossings.....	6.2
6.1.5 Environmental Consideration.....	6.2
6.1.6 Plans and Profiles	6.2
6.1.7 Obstruction and Damage of the Watercourse.....	6.3
6.1.8 Clearing.....	6.3
6.1.9 Excavation	6.3
6.1.10 Disposal of Excavated Materials.....	6.3
6.1.11 Permit Requirements & Underground Utilities	6.3

7.0 ASSESSMENTS.....	7.1
7.1 COST ESTIMATE	7.1
7.1.1 Re-Alignment Box Culvert Construction	7.1
7.1.2 Other Costs.....	7.2
7.1.3 Construction Cost	7.2
7.1.4 Allowances.....	7.2
7.1.5 Engineering.....	7.2

8.0 FUTURE MAINTENANCE.....	8.1
8.1 WORKING SPACE SECTION 63, THE DRAINAGE ACT, RSO	8.1

Table of Contents

LIST OF APPENDICES

APPENDIX A - Plan and Profile

APPENDIX B - Detail Drawings

APPENDIX C - Technical Background Report

1.0 Introduction

The proposed drainage realignment has been initiated under the provisions of Section 78 of the *Drainage Act* R.S.O. 1990 Chapter D.17, by the owners of 1410 Triole Street Ottawa Ontario (letter is attached). Stantec Consulting Ltd. (Stantec) was subsequently appointed under Section 8 of the *Drainage Act* by the City of Ottawa to prepare an Engineers Report in accordance with Sections 8 and 11 of the *Drainage Act*.

An on-site meeting, in accordance to Section 9 of the *Drainage Act*, was held on November, 3 2011 at the site of the proposed relocation. At that meeting the Engineer determined that the proposed works are required for the proposed industrial expansion to proceed. The realignment of the drain requires a new Engineers report be prepared.

With the adoption of this report, the owner will have the right to relocate the Drain, as set out in the report. The report deals with various aspects of the Drainage Act, including such items as location, environmental protection, inspection, costs allowances, grant structures, future maintenance, etc.

Once this Drainage By-law has been passed, the Municipality has no authority to alter the assessments or make revisions which alter the intent of the Report under the *Drainage Act*, RSO. It is therefore important that any desired changes relating to construction be requested at the Meeting to Consider the Engineer's Report.

The property owners are requested to examine the Report as it relates to their own properties, with particular attention to the location of properties and the location of the Drain.

The Schedules included in this Report deal with the following:

- Schedule "A" Plan and Profile
- Schedule "B" Detail Drawings or Figures
- Schedule "C" Technical Background Report .

2.0 History

“On October 11th, 1946, the Corporation of the Township of Gloucester adopted By-law No. 22 of 1946, entitled “By-law to provide for drainage work in the Township of Gloucester in the County of Carleton” and for borrowing on the credit of the municipality, the sum of Six Thousand, Five Hundred and Fifty-One and 90/100 dollars (\$6,551.90) for completing the same.

This by-law provided for drainage improvements of the watercourse known as the Choquette Award, which had been constructed approximately forty (40) years earlier. By adoption of the by-law, the Coquette Award drain becomes the South Cyrville (Municipal) Drain.

The engineer's report for the South Cyrville Municipal Drain was completed by N.B. McRostie, M.E.I.C. and called for the construction of a watercourse, with a bottom width of three feet (0.9m) and 1:1 side slopes.

In May 1993, the Regional Municipality of Ottawa-Carleton (RMOC) initiated an engineering and environmental review for the existing Snow Disposal Facility (SDF), located between Michael Street and Comstock Road in the cities of Ottawa and Gloucester.

In response, the City of Gloucester indicated that it required the deepening of the South Cyrville Municipal Drain to provide adequate outlet for future storm sewers in Michael and Triole Street (October 8, 1993). A similar requirement was imposed by the City of Ottawa (April 17, 1995). A request to increase the conveyance capacity of the channel was received from the City of Gloucester's Community Development Department (October 16, 1996). A further requirement to provide improved outlet for the area south of the CN/CP railway line was imposed by the City of Ottawa (July 23, 1996)⁽¹⁾.

The Engineers Report by Robinson Consultants Inc., for the reconstruction of the South Cyrville Municipal Drain is dated September 1997.

It is our understanding that the owners of 1410 Triole requested the City for permission to cover the drain, by way of a City permit in 1997, and the work was completed in 1998. The 1410 Triole owners apparently designed the enclosure with the intent of eventually putting a building over the drain.

By way of a July 15th, 2011 letter to the City of Ottawa, the 1410 Triole Street landowners (by way of their agent Ewald Zieger) requested that the South Cyrville Municipal Drain be relocated to facilitate the application for site plan approval (#DO-7-12-11-0009). The relocation includes a drain enclosure and all works are contained within the landowner's property.

(1) “Engineers Report for the Reconstruction of the South Cyrville Municipal Drain” prepared for the City of Gloucester by Robinson Consultants Inc. Consulting Engineers September 1997.

3.0 Watershed Characteristics

3.1 DRAINAGE AREA

“The South Cyrville Municipal Drain watershed has an area of approximately 300 ha. The area is almost completely urbanized although some agricultural land use remains along Kenaston Road. Over the years, urban development has resulted in changes to drainage patterns and watershed size, specifically:

- Construction of St. Laurent Boulevard has eliminated the upper portion of the channel.
- Construction of Highway 417 and development to the north has diverted some flow to Cummings Creek.
- Drainage from Innes Road between St. Laurent Boulevard and Highway 417 outlets directly to Green's Creek.

Soils within the watershed consist mainly of silty clay sand underlain bedrock shale of the Billings Formation. Boreholes and test pits which were advanced along the channel showed an overburden depth between 0.6 and 2.7m.

Land use within the watershed is mainly industrial/commercial. A small residential development is located in the Kenaston, Michael, Parisien, Marchand area and along Kenaston Road near Cyrville Road.”⁽²⁾

The South Cyrville Municipal Drain Watershed is shown in Appendix A as the drainage Area Plan.

The existing and relocated Drain is shown on the attached location plan, 1410 Triole site plan and profile (Schedule A).

⁽²⁾ “Engineers Report for the Reconstruction of the South Cyrville Municipal Drain” prepared for the City of Gloucester by Robinson Consultants Inc. Consulting Engineers September 1997.

3.2 ENVIRONMENTAL

Under **Section 6** of the *Drainage Act*, a public agency may request an environmental appraisal of the drains affect on the area, “the cost thereof shall be paid by the party who requested it”.

3.3 LEGAL AND SUFFICIENT OUTLET

In compliance with Section 15 of *Drainage Act R.S.O., 1990 Chapter D.17*, “Subject to section 32 (Allowance for damage due to insufficient outlet), the realigned Drain has “good and sufficient outlet” at Triole Street. At this location, according to the 1997 Robinson report; the South Cyrville Municipal Drain has sufficient capacity for a 25 year event without causing surcharging of culverts. Also the 100 year storm can be conveyed without causing road overtopping.

Bank overtopping could occur during the lesser storm events as a result of snow and ice or debris in the channel. Therefore, regular inspection and maintenance is recommended.

Should redevelopment within the watershed cause a significant increase in impervious area and/or reduce the time of concentration (i.e. increase peakflow), additional measures in the form of stormwater attenuation will be required to maintain the capacity of the drain to the indicated standards.” ⁽³⁾ page 19

The proposed infill development of 1410 Triole will not increase flows. Accordingly there is no requirement to provide measures in the form of stormwater attenuation.

⁽³⁾ Engineers Report for the Reconstruction of the South Cyrville Municipal Drain” prepared for the City of Gloucester by Robinson Consultants Inc. Consulting Engineers September 1997.

4.0 Area Requiring Drainage

This report is required to address the proposed re-alignment of a portion of the South Cyrville Municipal Drain in order to accommodate a proposed addition to an office/ware house building located at 1410 Triole Street in Ottawa.

The City was available at the onsite meeting to review the area requiring drainage and their future needs and requirements.

The possibility of lowering the drain at Triole Street was specifically discussed. Under this option the conflicts with the sanitary sewer were cost prohibitive and of no significant upstream advantage. Also under Section 26 of the Drainage Act lowering of the drain across Triole Street City Right of Way would be the responsibility of the City of Ottawa. For these reasons lowering of the profile grade was not considered further.

4.1 EXISTING DRAIN LOCATION

The portion of the municipal drain that is the subject of this report currently extends approximately 87 m, directly across 1410 Triole Street in an east/west direction. The drain begins at the outlet of a 1500 mm diameter concrete culvert crossing of St. Laurent Blvd., having an invert of 64.84 m. The 1500 mm culvert discharges to an open channel with a bottom width varying between about 1.5 and 1.8 m and having side slopes of between 1:1 and 6:1. The open channel extends about 7 m leading to the inlet of an 1800 x 900 mm concrete box culvert having an invert elevation of 64.94 m (0.10 m higher than outlet of the 1500 mm culvert). The box culvert flow in an easterly direction a distance of approximately 37 meters and has a longitudinal slope of 0.33%. It then discharges to an open channel with an average longitudinal slope of approximately 1.5%, with bottom width varying between about 0.7 m and 1.5 m and having grassed side slopes between 1:1 and 2.5:1. This channel leads to the inlet of a 1500 x 925 mm oval concrete culvert crossing under Triole Street having an invert elevation of 64.27 m.

5.0 Improvements and Recommendations

A covered Drain is employed in conjunction with an open Drain all in accordance with Section 14(2) of the Act.

City staff requires that the re-aligned drain be designed to the 1:100 year storm event. As per the 1997 Engineer's Report the peak flow rate at this location for the 1:100 event is 1.7 cu.m. per sec.

The hydraulic analysis of the proposed culvert was made using the HY-8 7.2 software developed by the US Federal Highway Administration. A tailwater elevation of 65.60 m was based on a 1:100 year headwater elevation of 65.25 m at Michael Street as identified in the 1997 Engineer's Report. The headwater elevation of the proposed culvert was increased by 0.04 m to account for the head loss in the bends in the culvert.

The headwater elevation at the culvert inlet was subsequently estimated at 65.80. It is pointed out that the finished floor elevation is 600mm higher than the 100 year HGL. However the owner can expect frequent flooding of the ramp, which sits at elevation 65.14 or approximately 650mm below the 100 year HGL. Other parts of the parking lot are below the 100 year flood level of 65.80 and may experience less frequent flooding.

5.1 PROPOSED DRAIN LOCATION

Re-alignment of the municipal drain around the proposed building addition will increase its length by 34 meters. The re-aligned drain commences at the 1500 mm diameter concrete culvert crossing of St. Laurent Blvd. From this point the culvert discharges into to a rip rap lined open channel having a longitudinal slope of 0.48%, a bottom width of 1.5 m and having 2:1 side slopes. This open channel will bend south and then east and extend about 23 m leading to the inlet of a proposed 1800 x 900 mm concrete box culvert. The box culvert will have a longitudinal slope of 0.47% and is 93.5 m in length. The box culvert will have two bends to re-align the drain around the proposed addition. The box culvert discharges to an open channel, 4 m in length, leading to the inlet of the existing 1500 x 925 mm oval concrete culvert crossing under Triole Street. The existing oval concrete culvert will be shortened by 4 m to accommodate the proposed re-alignment

In accordance with Section 19 of the Act, once the new realigned channel is in place, the existing channel and box culvert west of Triole Street to the St Laurent Blvd. embankment is no longer useful, and this engineers report includes for the abandonment of this portion of the Drain, as a Municipal Drain. The abandoned portion will be filled in with engineered fill as recommended by the geotechnical consultant. The abandoned ends of the old channel will include a clay seal to prevent water piping through the granular.

6.0 Design Recommendations

It is our recommendation that the watercourse be realigned in accordance with the accompanying Plans, Profile and Specifications. We feel that the recommendations in this report will provide the benefitting lands with the required land use advantages without impacting downstream flows or upstream hydraulics.

This report continues to provide Drainage Act status to the South Cyrville Municipal Drain all as described in the Engineers Report for the Reconstruction of the South Cyrville Municipal Drain prepared for the City of Gloucester by Robinson Consultants Inc., September 1997.

The following sections deal with the various aspects of Municipal Drainage as it relates to construction.

6.1 CONSTRUCTION PROVISIONS-GENERAL

The owner of 1410 Triole and the City of Ottawa having the Drain passing through their lands are requested to review all construction provisions for their lands, including earth disposal location, spoil pile disposal, rip rap locations, Box culvert location, and excavation location. Any request for changes to any of these provisions must be made at the Meeting to Consider the Engineers Report.

6.1.1 Design

The channelization work will consist of 23 meters of rip-rap open channel from the St Laurent Road embankment followed by 92.6 meters of 1800mm by 900mm concrete box culvert to Triole Street. All the said work is located within the 1410 Triole Street property.

The work will terminate just upstream of Triole Street, at chainage 0+120.2.

The Box Culvert reach of the Drain is to be a minimum of 3.00 meters from the building and will have a minimum of 0.5 meters of cover. The Right of way for future maintenance is shown on the Detail Plan view on drawing GD-1.

Site access will be via the 1410 Triole property entrance.

The South Cyrville Municipal Drain relocation will have the same hydraulic capacity as the downstream drain and the calculations indicate that it will have sufficient capacity for a 100 year event without causing surcharging of the St Laurent Blvd. culvert.

Bank overtopping could occur as a result of snow and ice or debris in the channel. Therefore, regular inspection and maintenance is recommended.

The flow calculations are based on runoff from existing land uses. Should redevelopment within the watershed cause a significant increase in impervious area and/or reduce the time of concentration (i.e. increase peakflow), additional measures in the form of stormwater attenuation will be required to maintain the capacity of the drain to the indicated standards.

6.1.2 Channel Section

The new channel/box culvert is to be constructed within the 1410 property limits. Where existing fences or vegetation must be removed for construction purposes, damaged areas will be reinstated. It is anticipated that the channel may be located in bedrock and overburden. Because the bedrock degrades rapidly when exposed to the atmosphere, side slopes no steeper than 2 horizontal to 1 vertical are recommended. Culvert inlets and outlets and sharp channel bends will be protected with rip-rap.

No buffer strips or fencing will be required. For future maintenance, a sufficient maintenance working space has been identified on the plan as part of this report in Appendix A.

6.1.3 Alignment

The channel alignment is noted on Drawing #GD-1. Changes in alignment are not allowed after the report is adopted by the municipality, therefore any relocation or changes must be established before the Meeting to Consider the Engineers Report.

6.1.4 Private Crossings

No future additional enclosures can be installed by the landowner without approval from the Municipality and an amendment to this report.

6.1.5 Environmental Consideration

Whenever possible the design includes measures which are intended to minimize environmental degradation.

Prior to construction and as the work progresses, sediment/erosion control measures are to be implemented by the Contractor to reduce the possibility of sediment being transported downstream. Sediment traps are required downstream of each excavation area.

6.1.6 Plans and Profiles

The plans show the general location of the works and adjacent lands and have been determined by use of Municipal records. The profiles show the dimensions, grades, and any other particulars of the works.

6.1.7 Obstruction and Damage of the Watercourse

Attention is drawn to Sections 80, 82 and 83 of the *Drainage Act* regarding responsibilities of owners with respect to the obstruction and damages to the Drain.

6.1.8 Clearing

Landowners are advised that the Contractor will clear only those trees, which may affect its operation within the working area. All trees having a diameter of 150 mm or greater shall be cleared of limbs and cut in reasonable length and neatly piled clear of the Drain so that the wood may be salvaged by the property owner. All brush, limbs, stumps and other debris resulting from the cleaning operation shall be piled on the adjacent lands and/or removed as directed by the landowners.

6.1.9 Excavation

Excavation of bedrock may be carried out using a hoe ram or ripper. No blasting is to take place.

6.1.10 Disposal of Excavated Materials

All excavated material, including rock, silt, debris, etc., will be removed and disposed of at an approved site.

In areas where excavated material is stockpiled, silt fencing will be erected to protect the drain. All landowners having the watercourse pass through their properties are asked to review the material disposal provision and make any request before the Meeting to Consider the Engineers Report.

6.1.11 Permit Requirements & Underground Utilities

It is expected that underground utilities lines will be encountered during the construction. All necessary permits from Public Utilities and the Conservation Authorities will be obtained prior to work commencing.

In addition to the adoption of the Engineer's Report as a City of Ottawa by-law, the following permits/approvals are required:

- Rideau Valley Conservation Authority (RVCA). Permit for fill, construction, alteration to waterways (Ontario Regulation 174/06).
- Site Plan Approval from City of Ottawa.
- Department of Fisheries and Oceans (DFO)
- Ministry of Natural Resources (MNR)

7.0 Assessments

The following sections deal with the various aspects of Municipal Drainage as it relates to costs, allowances, grant structure and assessments.

The Drainage Act requires that the total estimated cost be assessed to the affected lands and roads under the categories of benefit (Section 22), outlet liability (Section 23) injuring liability (Section 23), special benefit (Section 24), and special assessment (Section 26). No assessment for injuring liability is applicable to this project.

For this project, the following special condition applies:

1. Lands assessed will only be charged under the special provision (Section 24) and not under Section 22. Therefore, all the costs, including the cost of preparing this Engineer's Report, are assessed to the individual property owner of 1410 Trioie Street. This statement shall be the Schedule of Assessment

7.1 COST ESTIMATE

Increases over the estimated cost are covered under section 59 of the Act. The contingencies are set at 15%.

Included in the cost estimate is a 15% contingency allowance that may be applied towards unforeseen extra costs.

7.1.1 Re-Alignment Box Culvert Construction

Supply and Install Box Culvert including 3 manhole egresses, 2 headwalls, rip-rap, watermain insulation, removal of the existing culvert and removals ads required	\$300,000	
Rock work (estimated)	\$15,000	
Sub Construction Cost (Main Drain)		\$315,000

**ENGINEERS REPORT FOR THE IMPROVEMENT OF THE SOUTH CYRVILLE MUNICIPAL DRAIN
LOCATED AT 1410 TRIOLE STREET, OTTAWA, ONTARIO**

7.1.2 Other Costs

Sub Construction Cost (Main Drain)		\$315,000.00
Engineer's Report including meetings	\$20,000.00	
Plans and Profile Drawings	\$4,500.00	
Contract Administration and Supervision	\$4,500.00	
Carrying Costs	\$1,000.00	
SUB-TOTAL (Other Costs)	\$30,000.00	\$30,000.00
Construction Contingency Allowance 15 %	\$52,000.00	\$52,000.00
Total Estimated Cost		\$397,000.00

HST is extra

7.1.3 Construction Cost

The construction cost is a tender cost received from the representative of the owners of 1410 Triole Street. The cost will be subject to final construction costs, including rock and contaminated soil extras which are not known, but will be paid for by the 1410 Triole Street owners.

7.1.4 Allowances

The *Drainage Act* provides that the Engineer shall estimate and allow money to the owners for any land that is necessary to use for construction of improvements and for disposal of material removed from the drainage works or for damages to the land.

Allowances are to be provided for right-of way (Section 29) access and damage or limitations to land or crops, (Section 30).

There are no allowances under this report.

7.1.5 Engineering

The Engineering cost estimate is divided into three parts; preparation of a final Engineer's Report preparation (including all meetings), preparation of Plans and Profile drawings, and Contract Administration and Supervision.

The engineers cost related to possible tribunal hearings, Ministry approvals or referring the report back to the engineer is not included in the estimate.

8.0 Future Maintenance

Future maintenance of the South Cyrville Municipal Drain will be the responsibility of the municipality as outlined in Section 74 of the Drainage Act. Individual owners shall be responsible for reporting any maintenance problems to the City of Ottawa Drainage Superintendent.

Under this section, future maintenance of the drain will be in accordance with the “Engineers Report for the Reconstruction of the South Cyrville Municipal Drain” prepared for the City of Gloucester by Robinson Consultants Inc. Consulting Engineers September 1997. The cost of maintenance for the culvert located on the property of 1410 Triole Street will be assessed in the same proportion as set out in the “Engineers Report for the Reconstruction of the South Cyrville Municipal Drain” prepared for the City of Gloucester by Robinson Consultants Inc. Consulting Engineers September 1997, Schedule B.

It is noted that in 2002 there was an amalgamation of the Regional Municipality of Ottawa Carleton, City of Gloucester, and the City of Ottawa, now known as the City of Ottawa. Accordingly, the maintainers of the South Cyrville Municipal Drain under the terms of the 1997 Report, shall be the City of Ottawa.

The Contractor shall be responsible for making good any construction defects found in the work for a period of one year from the date of final acceptance of the work.

8.1 WORKING SPACE SECTION 63, THE DRAINAGE ACT, RSO

To provide access for construction equipment to the site, a plan which shows available working areas and entry points is included on the plan and profile sheet.

Any damage to adjacent properties which may result from construction activities will be repaired by the Contractor.

In general, the working space as defined under section 63 shall be 3 meters from the north and west sides of the box culvert and/or channel edges and extend to the south and east to the property limits. All as indicated on the Plan and Profile sheet attached to this report.

This provision allows the City’s Drainage Superintendent access to the affected lands for maintenance and/or repair/replacement purposes.

All of which is respectively submitted,

John vanGaal, P. Eng.

Date

Stantec



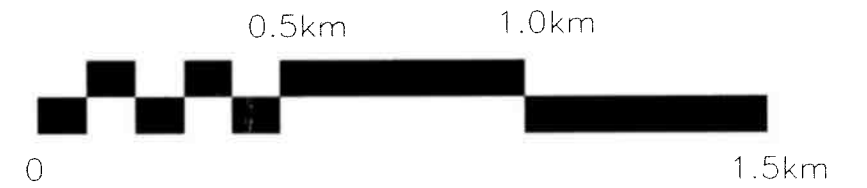
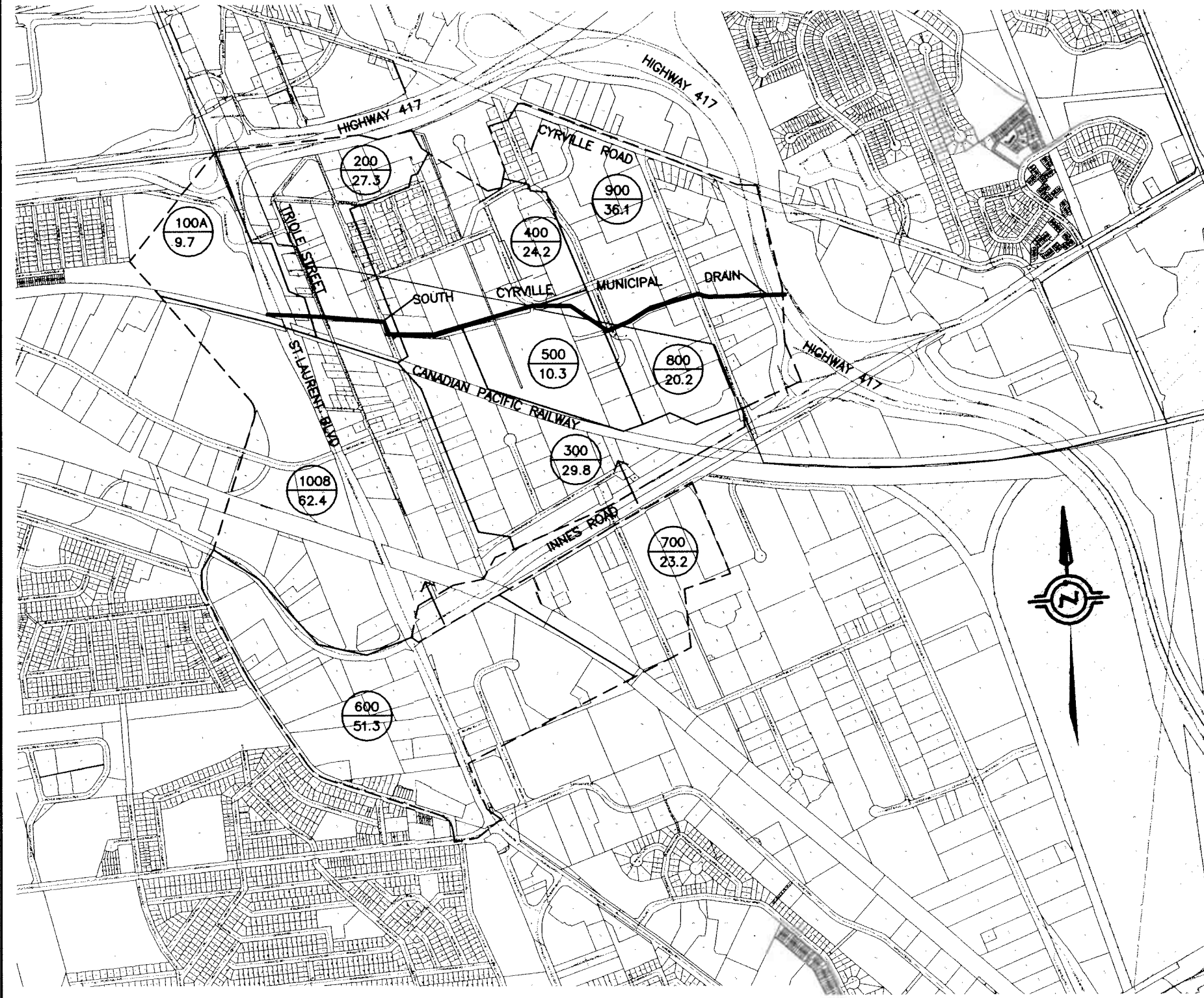

**ENGINEERS REPORT FOR THE IMPROVEMENT OF THE SOUTH CYRVILLE MUNICIPAL DRAIN
LOCATED AT 1410 TRIOLE STREET, OTTAWA, ONTARIO**

**APPENDIX A
Plan and Profile**

DRAINAGE AREA PLAN



LEGEND

-  SUB CATCHMENT AREA
DRAINAGE AREA (H_a)
-  SUB CATCHMENT BOUNDARY
-  WATERSHED BOUNDARY
-  FLOW PATH

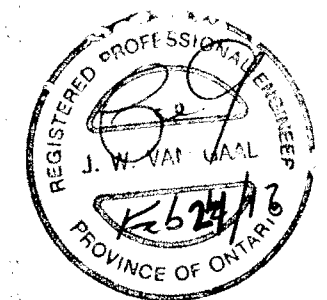

KEY PLAN

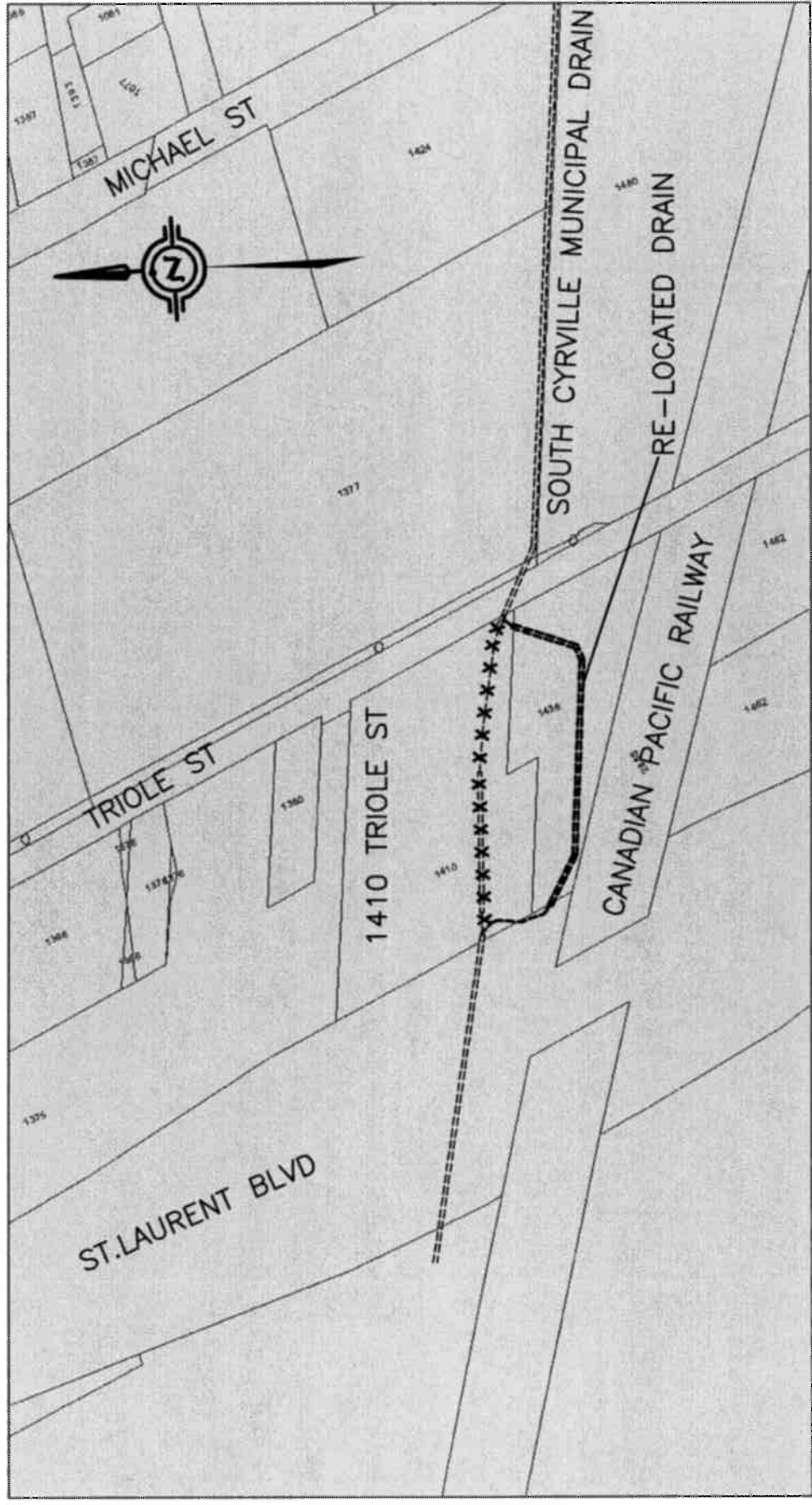
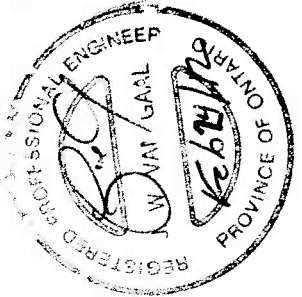

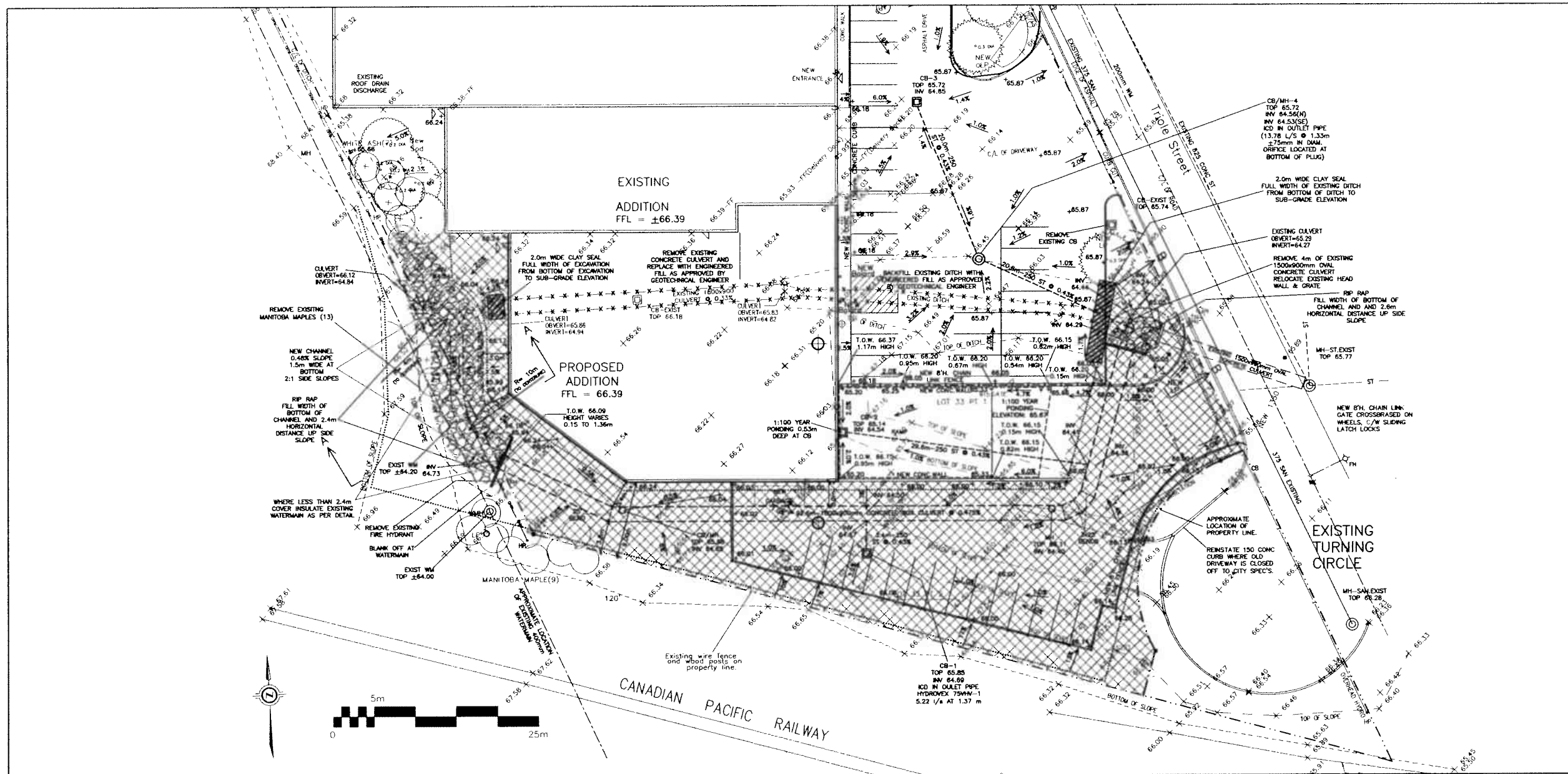

DRAWING LEGEND

- CB CATCH BASIN
- MH MANHOLE
- CB/MH CATCH BASIN/MANHOLE
- PH FIRE HYDRANT
- UP UTILITY POLE
- EXISTING GRADE ELEVATION
- +93.79 PROPOSED GRADE ELEVATION
- SLOPE OF GRADE
- SWALE/DITCH (CENTERLINE)
- SALT FENCE BARRIER
- PROPERTY LINE
- FUTURE WORKING SPACE AS PER SECTION 63 OF DRAINAGE ACT

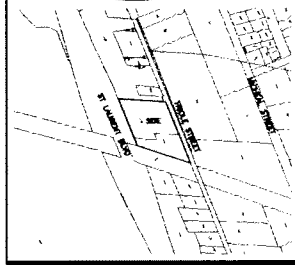
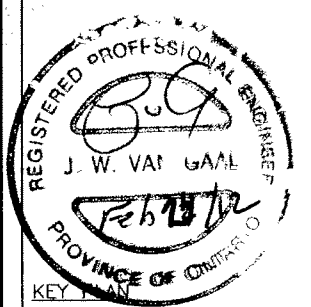

No.	Date	REVISION
4	FEB 7-12	REVISED AS PER STANTEC'S COMMENTS RE-ISSUED FOR APPROVAL
3	JAN 24-12	REVISED AS PER STANTEC'S COMMENTS RE-ISSUED FOR APPROVAL
2	DEC 20-11	ISSUED FOR APPROVAL
1	MAY 5-11	ISSUED FOR APPROVAL

D. B. GRAY ENGINEERING INC.
 Professional Engineers - Consulting & Design - Survey & Mapping Services - Estimators
 1052 Karsh Drive, Ottawa, Ontario, K1G 4N1
 Tel: (613) 249-8844, Fax: (613) 249-9815, email: d.gray@dogrn.com

Project: **RE-LOCATION OF MUNICIPAL DRAIN & NEW CULVERT 1410 TRIOLE STREET OTTAWA, ONTARIO.**

PLAN AND PROFILE

Engineer's Seal:

Drawn: D.B.G.
 Hor. Scale: 1:250
 Vert. Scale: 1:50
 Date: MAY 5-11
 Job: 10044

Drawing No: **GD-1 of 2**

NOT VALID UNLESS SIGNED & DATED

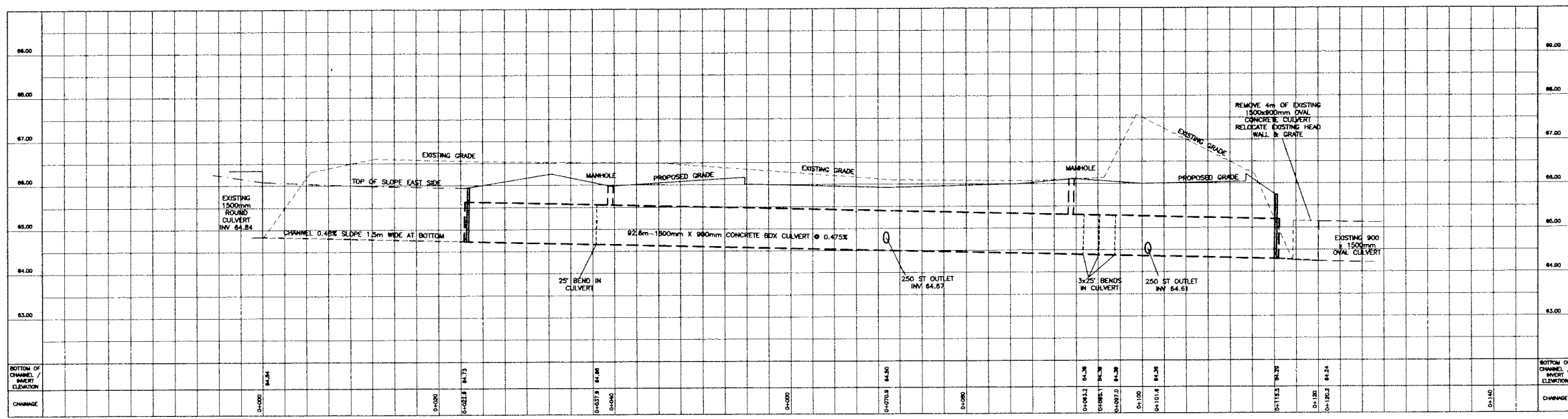

Stantec

**ENGINEERS REPORT FOR THE IMPROVEMENT OF THE SOUTH CYRVILLE MUNICIPAL DRAIN
LOCATED AT 1410 TRIOLE STREET, OTTAWA, ONTARIO**

**APPENDIX B
Detail Drawings**

- GENERAL
 - USE IMP SCALE TO CONFIRM ACTUAL PLOT SCALE.
 - EXISTING AND NEW ELEVATIONS AND INVERTS SHOWN ARE GEOMETRIC AND ARE IN METERS.
 - EXISTING ELEVATIONS AND LOCATIONS, INVERTS AND SIZES OF EXISTING SERVICES ARE NOT NECESSARILY SHOWN ON PLAN AND THOSE SHOWN ARE DERIVED FROM AVAILABLE INFORMATION AND MUST BE CONFIRMED ON SITE BEFORE COMMENCING CONSTRUCTION. REPORT ANY DIFFERENCES TO ENGINEER.
 - REFER TO ARCHITECTURAL / LANDSCAPE SITE PLANS FOR EXACT LOCATIONS OF BUILDINGS, PAVED AREAS, SIDEWALKS ETC.
 - REFER TO THE LATEST REVISION AND ALL ADDENDUMS OF THE GEOTECHNICAL INVESTIGATION.
 - DRAWINGS ARE TO BE READ IN CONJUNCTION WITH DRAINAGE REPORT NO. 10044-00 PREPARED BY D. B. GRAY ENGINEERING INC. DATED DECEMBER 2011.
 - REINSTATE ADJACENT PROPERTIES TO PRE-CONSTRUCTION CONDITIONS.
 - REINSTATE CITY PROPERTIES TO CITY STANDARDS AND TO CITY OF OTTAWA'S SATISFACTION.
 - ALL CITY PROPERTY, DAMAGED AS A RESULT OF THIS WORK, SHALL BE REINSTATED TO THE CITY'S SATISFACTION.
 - ALL RELIEF WORK SHALL BE DONE IN ACCORDANCE WITH CURRENT CITY STANDARDS AND SPECIFICATIONS.
 - 111 ONTARIO PROVINCIAL STANDARDS & SPECIFICATIONS WILL APPLY WHERE NO CITY STANDARDS ARE AVAILABLE.

- PROGRAM AND SEWAGE CONTROL
 - THE CONTRACTOR SHALL IMPLEMENT BEST MANAGEMENT PRACTICES TO PROVIDE FOR PROTECTION OF THE AREA DRAINAGE SYSTEM AND THE RECEIVING WATER COURSE DURING CONSTRUCTION ACTIVITIES. THIS INCLUDES LIMITING THE AMOUNT OF EXPOSED SOIL, USING FILTER CLOTH UNDER THE GRATE OF CATCH BASINS AND MANHOLES COVERED AND INSTALLING SILT FENCES AND OTHER EFFECTIVE SEDIMENT TRAPS.
 - PRIOR TO COMMENCEMENT OF CONSTRUCTION INSTALL A SILT FENCE BARRIER AS SHOWN ON PLANS. RESPECT ALL SILT FENCES AT THE END OF EACH DAY AND AFTER EACH RAINFALL. REMOVE SEDIMENT DEPOSITS WHEN THE LEVEL OF DEPOSITS REACHES ONE THIRD THE HEIGHT OF THE FENCE. IMMEDIATELY REPAIR OR REPLACE ANY DAMAGED SECTIONS OF FENCE. DO NOT REMOVE ANY SILT FENCES IN ANY PHASE UNTIL CONSTRUCTION IS COMPLETE.
 - PRIOR TO COMMENCEMENT OF CONSTRUCTION, AT ALL MANHOLE CATCH BASINS ADJACENT TO THE SITE AND AT ANY MANHOLES OR CATCH BASINS THAT WILL RECEIVE DISCHARGE FROM WATERING OPERATIONS AND ALL NEW CATCH BASINS AS THEY ARE INSTALLED, PLACE GEOTEXTILE FABRIC BETWEEN THE GRATE AND FRAME. REMOVE GEOTEXTILE FABRIC UNTIL CONSTRUCTION IS COMPLETE.
 - CONSTRUCTION IS CONSIDERED COMPLETE WHEN THE FOLLOWING CONDITIONS HAVE BEEN MET:
 - ALL STRUCTURES HAVE BEEN BUILT.
 - ALL HARD SURFACES HAVE BEEN CONSTRUCTED.
 - ALL PROPOSED GRASSED AREAS ARE EITHER SOODED OR HAVE A FULL COVERAGE OF WELL ESTABLISHED TURF AND HAVE HAD A MINIMUM OF ONE FULL GROWING SEASON (MAY 15TH TO SEPTEMBER 15TH).
 - THERE ARE NO AREAS OF EXPOSED EARTH.
 - ALL STOCKPILED MATERIALS HAVE BEEN REMOVED.

- GRADING & DRAINAGE
 - NEW GRADIES TO MATCH EXISTING AT PROPERTY LINE.
 - ALL AREAS SHALL BE GRADIED TO PRODUCE ADEQUATE DRAINAGE AWAY FROM BUILDINGS TO CATCH BASINS, SWALES, DITCHES AND OTHER APPROVED DISPOSAL AREAS. GRADIES TO BE GRADIED BETWEEN FINISHED SPOT ELEVATIONS SHOWN IN DRAWINGS TO PREVENT PONDING (OTHER THAN PONDING REQUIRED FOR STORMWATER MANAGEMENT).
 - PROVIDE A MALET TYPE GRATE (VERTICAL BARS) AT THE INLET AND AN OUTLET TYPE GRATE (HORIZONTAL BARS) AT THE OUTLET OF ALL CULVERTS.
 - NEW CULVERTS SHALL BE PRECAST CONCRETE TO OOPS 1421 AND SHALL BE DESIGNED TO WITHSTAND HEAVY VEHICLE LOADS.
 - MANHOLE STEPS TO OOPS 405.01
 - FRAMES, GRATES AND COVERS TO OOPS 1850 AND CITY OF OTTAWA STANDARDS. GRATES AND COVERS TO BEAR EVENLY ON FRAMES. PAINTED WITH ONE SHOP COAT OF ASPHALT OR TAP BASE BLACK. ALL JOINTS AND CREVICES SHALL BE THOROUGHLY COATED.
 - PROVIDE A MALET TYPE GRATE (VERTICAL BARS) AT THE INLET AND AN OUTLET TYPE GRATE (HORIZONTAL BARS) AT THE OUTLET OF ALL CULVERTS.
 - RIP RAP: PLACE RIP-RAP TO THICKNESS AND DETAILS AS INDICATED. USE QUARRIED STONE 300mm to 350mm IN DIAMETER. AREA TO BE RIP RAPPED SHALL BE EXCAVATED AND FINE GRADIED TO A UNIFORM AND EVEN SURFACE TO PROVIDE ADEQUATE FOUNDATION. FILL AND THOROUGHLY COMPACT DEPRESSIONS. WHERE RIP RAP IS TO BE PLACED ON SLOPES, EXCAVATE TRENCH AT TOE OF SLOPE. PLACE GEOTEXTILE FABRIC ON PREPARED SURFACE. PLACE RIP RAP ON FABRIC CAREFULLY, TO AVOID PUNCTURING FABRIC. PLACE RIP RAP IN A SET AND STABLE MANNER. ROCK SHALL BE PLACED STARTING AT THE LOWER END OF THE SLOPE. THE LARGEST ROCKS OBTAINABLE SHALL BE USED AND PLACED IN THE BOTTOM COURSES AND FOR USE AS HEADERS THROUGH SUBSEQUENT COURSES. THEY SHALL BE LAD CLOSELY AND SUCH THAT THEY WILL PROVIDE A REASONABLE STABILIZATION OF COURSES. FILL VOIDS WITH ROCK SPALLS OR COBBLES. FINISH SURFACE EVEN, FREE OF LARGE OPENINGS AND HEAT IN APPEARANCE.
 - GEOTEXTILE FABRIC TO OOPS 1480. 100% SYNTHETIC FIBRE FABRIC SHALL BE USED IN SILT FENCE BARRIER AND BETWEEN GRATES FRAMES OF CATCH BASINS. NON-WOVEN SYNTHETIC FIBRE FABRIC, 75mm THICK, 200g/m² SHALL BE USED FOR MATERIAL SEPARATION. GEOTEXTILE (FILTER) FABRIC SHALL BE FREE OF TEARS AND RESISTANT TO DEGRADATION BY ULTRA VIOLET AND HEAT EXPOSURE. PLACE GEOTEXTILE MATERIAL BY UNROLLING OVER GRADIED SURFACE, SMOOTH AND FREE OF TENSILE STRESSES, WRINKLES AND CREASES. PLACE GEOTEXTILE MATERIAL ON SLOPING SURFACES IN ONE CONTINUOUS LENGTH FROM TOE OF SLOPE TO UPPER EXTENT OF GEOTEXTILE OVERLAP EACH EXISTIVE STRIP OF GEOTEXTILE 300mm OVER PREVIOUSLY Laid STRIP IN DIRECTION OF FLOW. ALTERNATIVELY THE FABRIC MAY BE LAPPED A MINIMUM OF 300mm AND Pinned TOGETHER. PROTECT INSTALLED GEOTEXTILE MATERIAL FROM DISPLACEMENT, DAMAGE OR DEGRADATION BEFORE, DURING AND AFTER PLACEMENT OF MATERIAL LAYERS AFTER INSTALLATION, COVER WITH OVERLAPPING LAYER WITHIN 4 HOURS OF PLACEMENT. DURING DELAY AND STORAGE, PROTECT GEOTEXTILES FROM DIRECT SUNLIGHT, ULTRAVIOLET RAYS, EXCESSIVE HEAT, WIND, DIRT, DUST, DEBRIS AND ROCKETS. VEHICULAR TRAFFIC NOT PERMITTED DIRECTLY ON GEOTEXTILE. AVOID PUNCTURING GEOTEXTILE. REPLACE DAMAGED OR DEGRADATED GEOTEXTILE.

- CONSTRUCTION
 - PRIOR TO COMMENCING WORK:
 - OBTAIN AND PAY FOR ALL NECESSARY PERMITS AND APPROVALS FROM THE AUTHORITIES.
 - SIZE, DEPTH AND LOCATION OF EXISTING UTILITIES AND STRUCTURES AS INDICATED ARE FOR GUIDANCE ONLY. EXISTING UTILITIES AND STRUCTURES ARE NOT NECESSARILY SHOWN ON PLANS. COMPLETENESS AND ACCURACY ARE NOT GUARANTEED. NOTIFY ALL APPLICABLE OWNERS, UTILITY COMPANIES AND AUTHORITIES HAVING JURISDICTION OF PROPOSED WORK AND LOCATE AND CLEARLY IDENTIFY ALL EXISTING SERVICES, UTILITIES AND STRUCTURES ON AND ADJACENT TO SITE. CONFIRM LOCATIONS OF EXISTING UTILITIES BY CAREFUL TEST EXCAVATIONS AND REPORT ANY DIFFERENCES TO THE ENGINEER.
 - COORDINATE AND SCHEDULE WORK WITH THE AUTHORITIES AND OTHER TRADES.
 - MAINTAIN AND PROTECT FROM DAMAGE, SERVICES, UTILITIES AND STRUCTURES ENCOUNTERED.
 - PROTECT EXISTING BUILDINGS, TREES AND OTHER PLANTS, LAWNS, FENCING, SERVICE POLES, WIRES, FENCING, SURVEY BENCH MARKS AND MONUMENTS AND OTHER SURFACE FEATURES FROM DAMAGE WHILE WORK IS IN PROGRESS. DO NOT DISTURB SOIL WITHIN BRANCH SPREAD OF TREES OR SHRUBS THAT ARE TO REMAIN.
 - PROVIDE TRAFFIC CONTROL AND SAFETY MEASURES INCLUDING ANY NECESSARY PERSONNEL AND THE SUPPLY, INSTALLATION AND REMOVAL OF ALL NECESSARY SIGNS AND BARRIERS.
 - REMOVE OBSTRUCTIONS, ICE AND SNOW FROM SURFACES TO BE EXCAVATED.
 - CUT PAVEMENT AND / OR SIDEWALK NEATLY ALONG LIMITS OF PROPOSED EXCAVATION IN ORDER THAT SURFACE MAY BE REPAIRED AND CLEANED.
 - STOCKPILE GRANULAR AND FILL MATERIALS IN MANNER TO PREVENT SEGREGATION AND PROTECT FROM CONTAMINATION.
 - EXCAVATION, TRENCHING & BACKFILL:
 - A SHORE AND BRACE EXCAVATIONS, PROTECT SLOPES AND BANKS AND PERFORM ALL WORK IN ACCORDANCE WITH OCCUPATIONAL HEALTH AND SAFETY ACT AND OTHER AUTHORITIES HAVING JURISDICTION.
 - KEEP EXCAVATIONS FREE OF WATER WHILE WORK IS IN PROGRESS. PROTECT OPEN EXCAVATIONS AGAINST FLOODING AND DAMAGE DUE TO SURFACE RUN-OFF 3.1.3 EXCAVATION MUST NOT INTERFERE WITH BEARING CAPACITY OF ADJACENT FOUNDATIONS.
 - DO NOT OBSTRUCT FLOW OF SURFACE DRAINAGE OR NATURAL WATERCOURSES.
 - EXCAVATE TO LINES, GRADES, ELEVATIONS AND DIMENSIONS AS INDICATED. DISPOSE OF SURPLUS AND UNSUITABLE EXCAVATED MATERIAL OFF SITE.
 - EARTH BOTTOMS OF EXCAVATIONS TO BE UNDISTURBED SOIL, LEVEL, FREE FROM LOOSE, SOFT OR ORGANIC MATTER.
 - ALL STRUCTURES WITHIN PAVED AREAS SHALL HAVE 4:1 FROST TAPERS FROM FROST LINE TO SUB-GRADE.
 - CORRECT OVER-EXCAVATION WITH GRANULAR 'A' COMPACTED TO NOT LESS THAN 95 % OF CORRECTED MAXIMUM DRY DENSITY.
 - SUB-GRADE AND AREAS TO BE BACKFILLED TO BE FREE FROM DEBRIS, SNOW, ICE, WATER AND FROZEN GROUND.
 - DO NOT USE BACKFILL MATERIAL WHICH IS FROZEN OR CONTAINS ICE, SNOW OR DEBRIS.
 - BEDDING MATERIAL FOR CULVERT SHALL BE OOPS 'A' SURROUND MATERIAL FOR WATERMAIN AND WATER SERVICE CONNECTIONS SHALL BE OOPS 'A' OR OOPS 'M'.
 - DO NOT USE BEDDING, SURROUND OR BACKFILL MATERIAL WHICH IS FROZEN OR CONTAINS ICE, SNOW OR DEBRIS.
 - PIPE BEDDING SHALL BE 150mm THICK. SHAPE BED TRUE TO GRADE AND TO PROVIDE CONTINUOUS, UNIFORM BEARING SURFACE FOR PIPE.
 - PLACE SURROUND MATERIAL AROUND PIPES TO FULL WIDTH OF TRENCH AND TO 300mm ABOVE PIPES.
 - PLACE BEDDING AND SURROUND AND BACKFILL MATERIAL IN UNIFORM LAYERS NOT EXCEEDING 150mm COMPACTED THICKNESS. PLACE FILL AND BACKFILL MATERIAL IN UNIFORM LAYERS NOT EXCEEDING 300mm COMPACTED THICKNESS.
 - COMPACT EACH LAYER TO 95% CORRECTED DRY DENSITY BEFORE PLACING SUCCEEDING LAYER.
 - DO NOT BACKFILL AROUND OR OVER CAST-IN-PLACE CONCRETE WITHIN 24 HOURS AFTER PLACING OF CONCRETE.
 - HANDLE USING METHODS APPROVED BY MANUFACTURER.
 - LAY, CUT AND JOIN IN ACCORDANCE WITH MANUFACTURER'S RECOMMENDATIONS.
 - SET PRECAST CONCRETE BASE ON 150mm MINIMUM OF GRANULAR BEDDING COMPACTED TO 100% CORRECTED MAXIMUM DRY DENSITY.
 - LAY ON PREPARED BED, TRUE TO LINE AND GRADE, AND ENSURE EACH SECTION IS IN CONTACT WITH SHAPED BED THROUGHOUT ITS FULL LENGTH, FREE OF SAGS OR HIGH POINTS.
 - DO NOT EXCEED MAXIMUM JOINT DEFLECTION RECOMMENDED BY MANUFACTURER.
 - USE NON-SHRINK GROUT WHEN SUITABLE CASSETS ARE NOT AVAILABLE.
 - JOINTS SHALL BE STRUCTURALLY SOUND AND WATER-TIGHT.
 - MAINTAIN FLOW DURING CONSTRUCTION.
 - REPAIR OR REPLACE PIPE, PIPE JOINT OR BEDDING FOUND DEFECTIVE.
 - PLACE GRANULAR BACKFILL MATERIALS IN A UNIFORM LAYERS TO COMPACTED THICKNESS OF 150mm, COMPACT TO 95% CORRECTED MAXIMUM DRY DENSITY.
 - PLACE FRAME AND COVER AS INDICATED. IF ADJUSTMENT REQUIRED USE CONCRETE RINGS.
 - CLEAN LINES OF DEBRIS, FOREIGN AND SUPPLIES MATERIALS. REMOVE FINS AND SHARP PROJECTIONS. PREVENT DEBRIS FROM ENTERING SYSTEM.
 - TO MAINTAIN RECORD DRAWINGS AND RECORD ACCURATELY DEVIATIONS FROM THE ORIGINAL CONTRACT DOCUMENTS CAUSED BY SITE CONDITIONS AND CHANGES MADE BY CHANGE ORDER OR ADDITIONAL INSTRUNCTION. UPDATE DAILY AND MAKE AVAILABLE ON-SITE FOR REVIEW THROUGHOUT THE CONSTRUCTION PERIOD. MARK CHANGES IN RED INK. RECORD DRAWINGS SHALL INCLUDE BUT NOT NECESSARILY LIMITED TO CHANGES OF DIMENSION AND DETAIL, AND HORIZONTAL AND VERTICAL LOCATIONS OF UNDERGROUND STRUCTURES REFERENCED TO A PERMANENT SURFACE STRUCTURE.
 - REINSTATE PAVEMENTS AND SIDEWALKS DISTURBED BY EXCAVATION TO THICKNESS, STRUCTURE AND ELEVATION WHICH EXISTED BEFORE EXCAVATION.
 - CLEAN AND REINSTATE AREAS AFFECTED BY THE WORK.

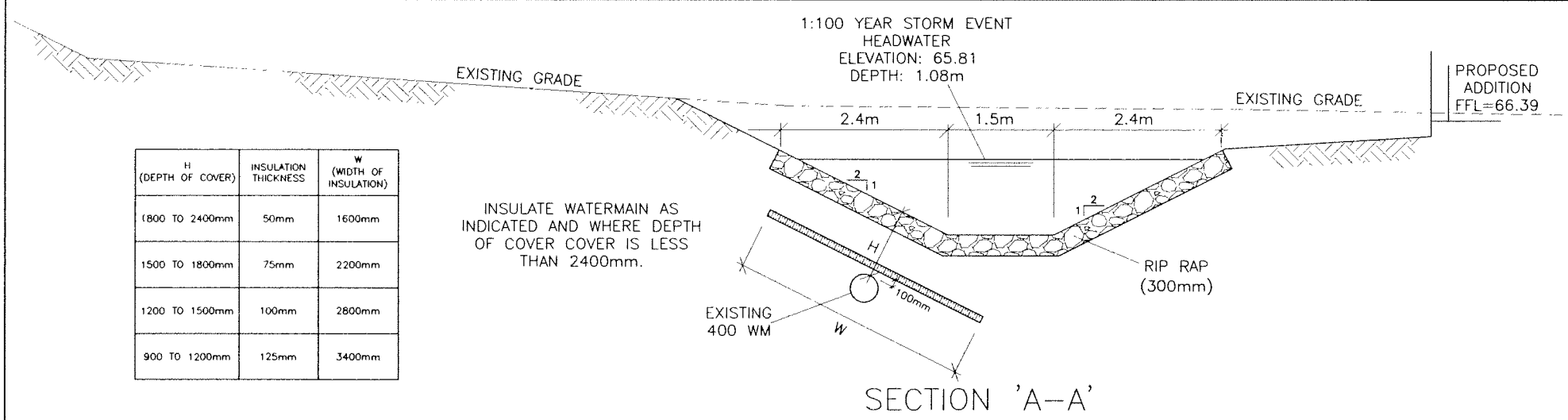

H (DEPTH OF COVER)	INSULATION THICKNESS	W (WIDTH OF INSULATION)
1800 TO 2400mm	50mm	1600mm
1500 TO 1800mm	75mm	2200mm
1200 TO 1500mm	100mm	2800mm
900 TO 1200mm	125mm	3400mm

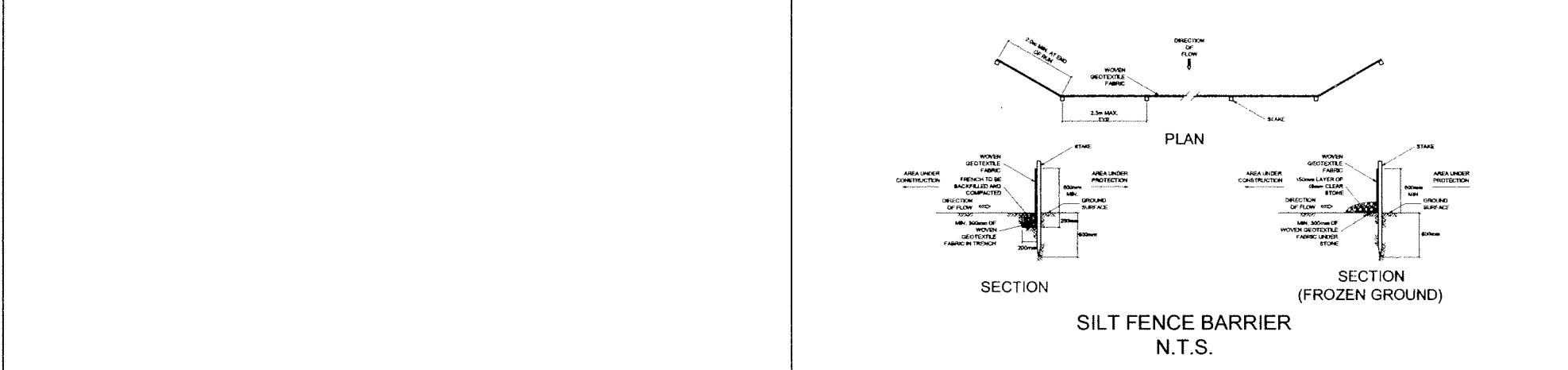
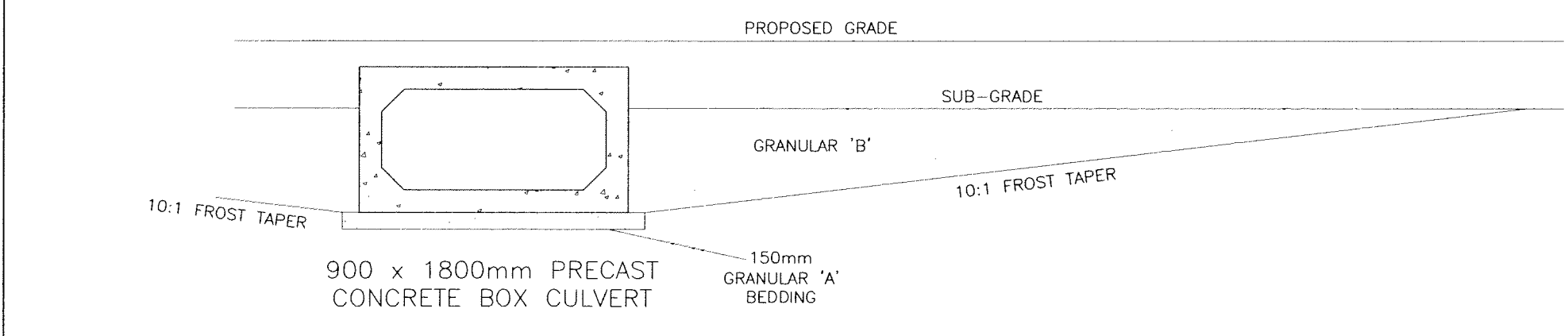
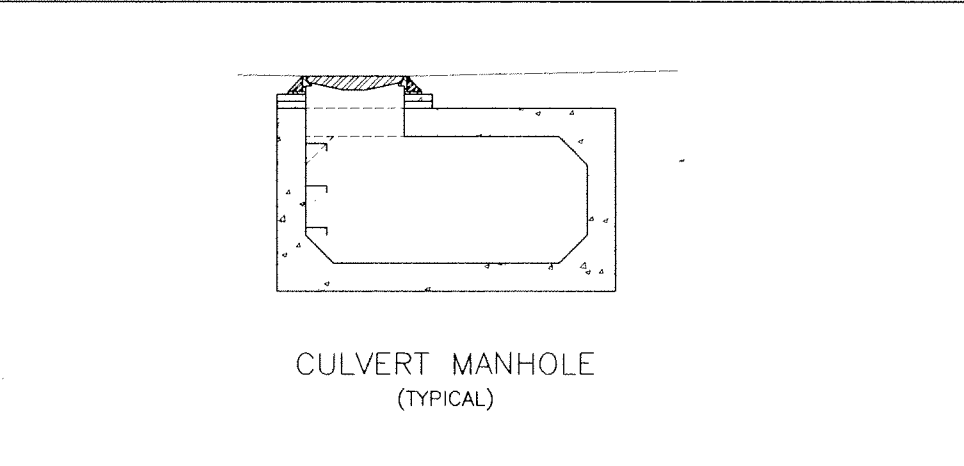
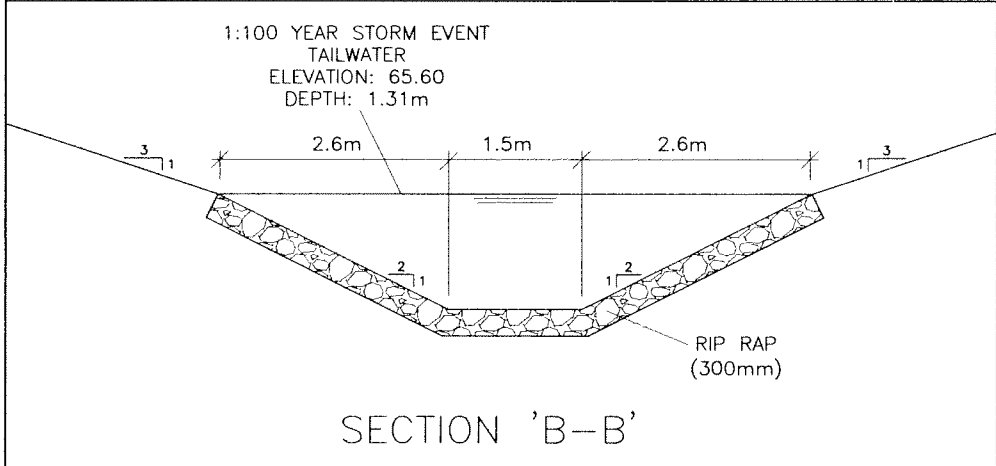

1:100 YEAR STORM EVENT
HEADWATER
ELEVATION: 65.81
DEPTH: 1.08m

EXISTING GRADE

EXISTING GRADE

PROPOSED ADDITION
FFL=66.39

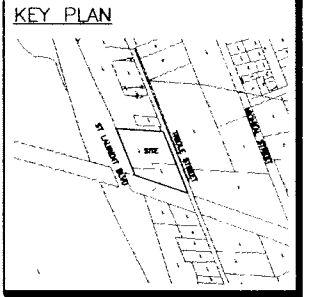
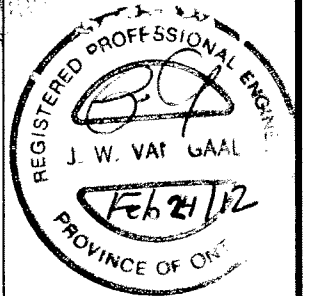

No.	Date	Revision
1	DEC 20-11	ISSUED FOR APPROVAL

D. B. GRAY ENGINEERING INC.
 1052 Karsh Drive
 Ottawa, Ontario, K1G 4N1
 Tel: (613) 249-8844
 Fax: (613) 249-9815
 email: dgray@regres.com

Project
RE-LOCATION OF MUNICIPAL DRAIN & NEW CULVERT
 1410 TRIOLE STREET
 OTTAWA, ONTARIO.

Drawing Title
NOTES & DETAILS

Engineer's Seal
 D.B. GRAY
 17006502
 DEC 20-11
 NOT VALID UNLESS SIGNED & DATED

Drawn: D.B.G.
 Hrd. Scale
 Vert. Scale
 Date: DEC 20-11
 Job: 10044

Drawing No.
GD-2
 of 2

Stantec

**ENGINEERS REPORT FOR THE IMPROVEMENT OF THE SOUTH CYRVILLE MUNICIPAL DRAIN
LOCATED AT 1410 TRIOLE STREET, OTTAWA, ONTARIO**

**APPENDIX C
Technical Background Report**

DRAINAGE REPORT

RE-ALIGNMENT OF A PORTION OF THE SOUTH CYRVILLE MUNICIPAL DRAIN LOCATED AT 1410 Triole Street Ottawa, Ontario

Report No. 10044-GD

December 20, 2011



NOT VALID UNLESS
SIGNED & DATED

D. B. GRAY ENGINEERING INC.

Stormwater Management - Grading & Drainage - Storm & Sanitary Sewers - Watermains

1052 Karsh Drive,
Ottawa, Ontario.
K1G 4N1

Tel: (613) 249-8044
Fax: (613) 249-9815
email: dbgray@rogers.com

DRAINAGE REPORT

RE-ALIGNMENT OF A PORTION OF THE SOUTH CYRVILLE MUNICIPAL DRAIN LOCATED AT 1410 Triole Street Ottawa, Ontario

This report addresses the proposed re-alignment of a portion of the South Cyrville Municipal Drain in order to accommodate a proposed addition to an office / warehouse building located at 1410 Triole Street in Ottawa.

Refer to drawing GD-1 (Revision 2: Dec 20-11) & GD-2 (Revision 1: Dec 19-11), prepared by D. B. Gray Engineering Inc. Also refer to THE Engineer's Report For the Reconstruction of the South Cyrville Municipal Drain, prepared by Robinson Consultants Inc. September 1997.

EXISTING DRAIN

The portion of the municipal drain that is the subject of this report currently extends approximately 87 m, essentially, directly across 1410 Triole Street in a east/west direction. The upstream end starts at the outlet of a 1500 mm diameter concrete culvert, having an invert of 64.84 m, located at the foot of the embankment of the St Laurent Boulevard overpass. The 1500 mm culvert discharges to an open channel with a bottom width varying between about 1.5 and 1.8 m and having side slopes of between 1:1 and 6:1. The open channel extends about 7 m leading to the inlet of an 1800 x 900 mm concrete box culvert having an invert elevation of 64.94 m (0.10 m higher than outlet of the 1500 mm culvert). The box culvert has a longitudinal slope of 0.33% and is approximately 37 m in length. The box culvert discharges to an open channel with an average longitudinal slope of approximately 1.5%, with bottom width varying between about 0.7 and 1.5 m and having grassed side slopes between 1:1 and 2.5:1. This channel leads the inlet of a 1500 x 925 mm oval concrete culvert crossing under Triole Street having an invert elevation of 64.27.

PROPOSED DRAIN

City staff requires that re-aligned drain be designed to the 1:100 year storm event. As per the 1997 Engineer's Report the peak flowrate at this location for the 1:100 event is 1.7 cu.m. per sec.

The channel flow is calculated using Manning's formula.

The hydraulic analysis of the proposed culvert was made using the HY-8 7.2 software developed by the US Federal Highway Administration. A tailwater elevation of 65.60 m

was based on a 1:100 year headwater elevation of 65.25 m at Michael Street as identified in the 1997 Engineer's Report. The headwater elevation of the proposed culvert was increased by 0.04 m to account for the head loss in the bends in the culvert.

To re-align the municipal drain around the proposed addition the route is increased by 34 m to about 121 m. At the upstream end at the 1500 mm diameter concrete culvert will discharge to a rip rap lined open channel having a longitudinal slope of 0.48%, a bottom width of 1.5 m and having 2:1 side slopes. This open channel will bend south and then east and extend about 23 m leading to the inlet of a proposed 1800 x 900 mm concrete box culvert. The box culvert will have a longitudinal slope of 0.47% and is 93.5 m in length. The box culvert will have two bends to re-align the drain around the proposed addition. The box culvert discharges to an open channel, 4.7 m in length, leading to the inlet of the existing 1500 x 925 mm oval concrete culvert crossing under Triole Street. The existing oval concrete culvert will be shortened by 4 m to accommodate the proposed re-alignment.

RE-ALIGNMENT OF A PORTION OF THE SOUTH
CYRVILLE MUNICIPAL DRAIN LOCATED AT
1410 Triole Street
Ottawa, Ontario

CHANNEL FLOW CALCULATIONS

One Hundred-Year Event

100 Year Flow (Q_{100}): 1.70 cu.m./s

Ditch Slope: 0.0048
Ditch Manning Roughness Coefficient n: 0.04 jagged irregular rock

Side Slope: 2 :1
Side Slope: 2 :1
Ditch Bottom Width: 1.50 m
Water Depth: 0.64 m

Water Top Width: 4.07
Water Cross-Section Area: 1.79 sq.m.
Wetted Perimeter: 4.38 m
Hydraulic Radius: 0.41 m

Velocity: 0.95 m/s Based on water depth
Velocity: 0.95 m/s Using Manning's Formula:

HY-8 Energy Dissipation Report

Scour Hole Geometry

Parameter	Value	Units
Select Culvert and Flow		
Crossing	1410 TRIOLE ST	
Culvert	NEW 1800x900 BOX CULVERT	
Flow	1.70	cms
Culvert Data		
Culvert Width (including multiple barrels)	1.8	m
Culvert Height	0.9	m
Outlet Depth	0.90	m
Outlet Velocity	1.05	m/s
Froude Number	0.35	
Tailwater Depth	1.31	m
Tailwater Velocity	0.00	m/s
Tailwater Slope (SO)	0.0047	
Scour Data		
Time to Peak		
Note:	if Time to Peak is unknown, enter 30 min	
Time to Peak	30.00	min
Cohesion	Noncohesive	
D16 Value	0.00	mm
D84 Value	0.00	mm
Tailwater Flow Depth after Culvert Outlet	Normal Depth	
Enter all required input before computation will occur		

HY-8 Analysis Results

Culvert Summary Table - NEW 1800x900 BOX CULVERT

Culvert Crossing: 1410 TRIOLE ST

Total Discharge (cms)	Culvert Discharge (cms)	Headwater Elevation (m)	Inlet Control Depth (m)	Outlet Control Depth (m)	Flow Type	Normal Depth (m)	Critical Depth (m)	Outlet Depth (m)	Tailwater Depth (m)	Outlet Velocity (m/s)	Tailwater Velocity (m/s)
0.00	0.00	65.60	0.00	0.87	0-NF	0.00	0.00	0.00	1.31	0.00	0.00
0.20	0.20	65.60	0.19	0.87	1-S1f	0.10	0.11	0.90	1.31	0.12	0.00
0.40	0.40	65.61	0.29	0.88	1-S1f	0.16	0.17	0.90	1.31	0.25	0.00
0.60	0.60	65.61	0.38	0.88	1-S1f	0.21	0.23	0.90	1.31	0.37	0.00
0.80	0.80	65.64	0.46	0.91	4-FFf	0.25	0.27	0.90	1.31	0.49	0.00
1.00	1.00	65.66	0.54	0.93	4-FFf	0.29	0.32	0.90	1.31	0.62	0.00
1.20	1.20	65.68	0.60	0.95	4-FFf	0.33	0.36	0.90	1.31	0.74	0.00
1.40	1.40	65.72	0.67	0.99	4-FFf	0.36	0.40	0.90	1.31	0.86	0.00
1.60	1.60	65.75	0.73	1.02	4-FFf	0.40	0.43	0.90	1.31	0.99	0.00
1.70	1.70	65.77	0.76	1.04	4-FFf	0.41	0.45	0.90	1.31	1.05	0.00
2.00	2.00	65.84	0.85	1.11	4-FFf	0.46	0.50	0.90	1.31	1.23	0.00

Crossing - 1410 TRIOLE ST, Design Discharge - 1.70 cms

Culvert - NEW 1800x900 BOX CULVERT, Culvert Discharge - 1.70 cms

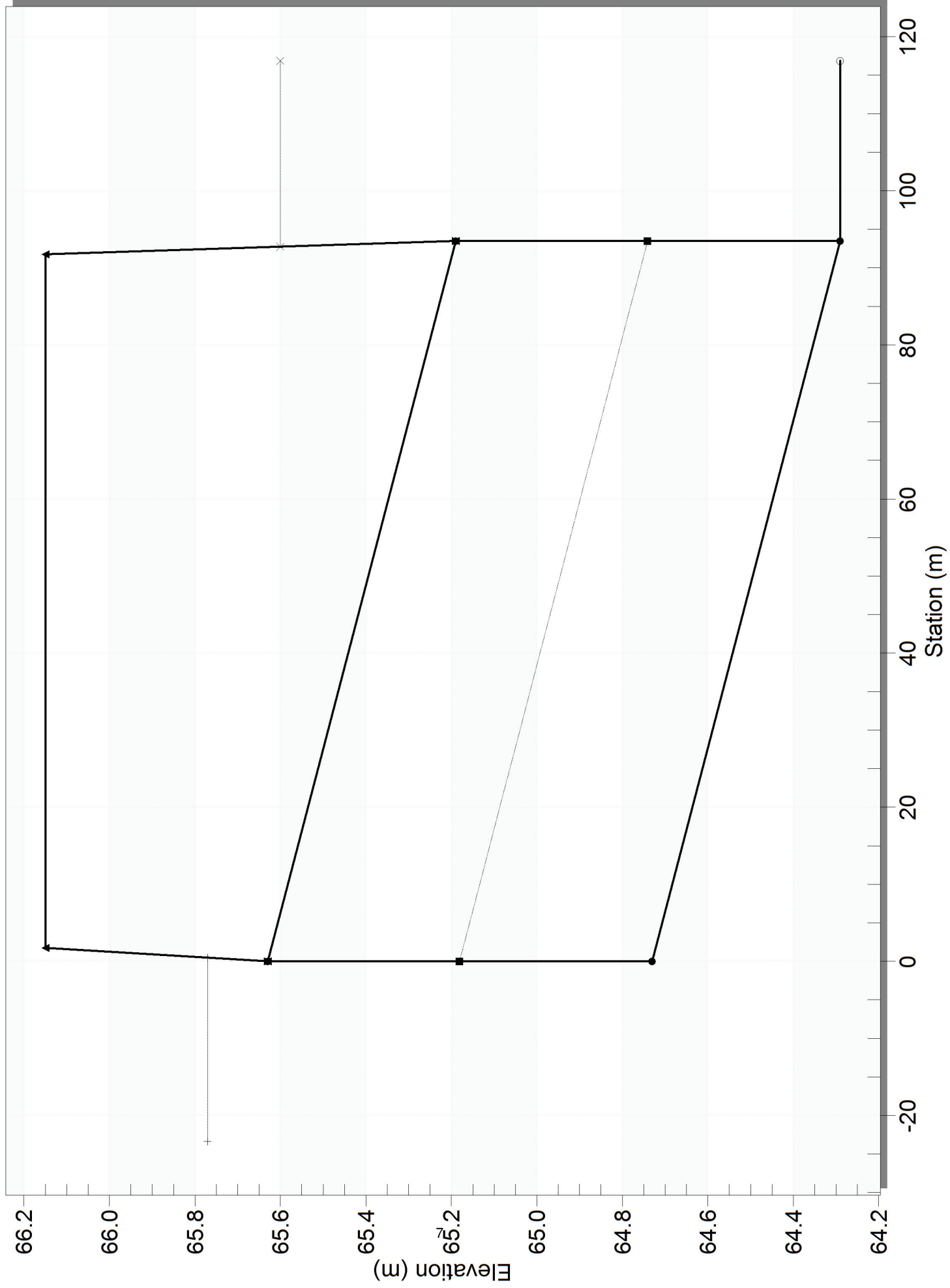

RE-ALIGNMENT OF A PORTION OF THE SOUTH
CYRVILLE MUNICIPAL DRAIN LOCATED AT
1410 Triole Street
Ottawa, Ontario

HEAD LOSS DUE TO BENDS IN CULVERTS
(IF OPERATING UNDER OUTLET CONTROL)

$$H_b = \frac{K_b V^2}{2g}$$

$$V = 1.05 \text{ m/s (outlet velocity)}$$

$$K_b = 0.46 \quad 75^\circ \text{ bend}$$

$$= 0.26 \quad 25^\circ \text{ bend}$$

$$H_b = 0.03 \text{ m for } 75^\circ \text{ bend}$$

$$H_b = 0.01 \text{ for } 25^\circ \text{ bend}$$

$$\text{TOTAL } H_b = 0.04 \text{ m}$$