

1. REHABILITATION OF POOLEY'S BRIDGE AND FIVE STONE ARCH BRIDGES -  
LEBRETON FLATS - PUBLIC HEARING

---

**COMMITTEE RECOMMENDATIONS**

Having held a public hearing, that Council:

1. **Approve the rehabilitation of Pooley's Bridge as a pedestrian/bicycle facility in accordance with Alternative 3B;**
2. **Authorize the Department to undertake necessary repairs to five other stone arch bridges in the area as noted in the report;**
3. **Authorize filing of an 'Application to Alter' to the City Of Ottawa for modifications relating to rehabilitation of Pooley's Bridge per the recommendation (1a) above, as required under provisions of the *Ontario Heritage Act*;**
4. **Authorize staff to undertake detailed design of the rehabilitation of Pooley's Bridge per recommendation (1a) above and repairs to five bridges over the aqueduct as outlined in recommendation (1b);**
5. **Authorize staff to undertake necessary utility relocations for this project.**

**DOCUMENTATION**

1. A/Co-ordinator, Transportation Committee report dated 21 Apr 99 is immediately attached.
2. The Ottawa River Runners submission undated immediately follows the report.
3. Extract of Draft Minute, Transportation Committee, 5 May 1999 will be distributed prior to Council and will include a record of the vote.

REGION OF OTTAWA-CARLETON  
RÉGION D'OTTAWA-CARLETON

REPORT  
RAPPORT

---

Our File/N/Réf.            03-07-99-0099  
Your File/V/Réf.

DATE                        21 April 1999

TO/DEST.                 Transportation Committee

FROM/EXP.                A/Committee Co-ordinator

SUBJECT/OBJET         **REHABILITATION OF POOLEY'S BRIDGE AND FIVE STONE  
ARCH BRIDGES - LEBRETON FLATS:  
PUBLIC HEARING**

---

### **REPORT RECOMMENDATIONS**

**That Transportation Committee recommend Council:**

- 1.     Approve the rehabilitation of Pooley's Bridge as a pedestrian/bicycle facility in accordance with Alternative 3B;**
- 2.     Authorize the Department to undertake necessary repairs to five other stone arch bridges in the area as noted in the report;**
- 3.     Authorize filing of an 'Application to Alter' to the City Of Ottawa for modifications relating to rehabilitation of Pooley's Bridge per the recommendation (1a) above, as required under provisions of the *Ontario Heritage Act*;**
- 4.     Authorize staff to undertake detailed design of the rehabilitation of Pooley's Bridge per recommendation (1a) above and repairs to five bridges over the aqueduct as outlined in recommendation (1b);**
- 5.     Authorize staff to undertake necessary utility relocations for this project.**

### **BACKGROUND**

At its meeting of 7 Apr 99, the Transportation Committee approved the attached report dated 19 Mar 99 from the Director, Engineering Division.

The project was advertised in the three (3) daily newspapers on April 9, 16, 23 and 30, 1999. As of the writing of this report, no objections were received.

Pending the results of the Public Hearing, the Committee's recommendations will be forwarded to Council for final approval on 26 May 99.

*Approved by  
M. J. Beauregard  
for Rosemary Nelson*

Attach:

REGION OF OTTAWA-CARLETON  
RÉGION D'OTTAWA-CARLETON

REPORT  
RAPPORT

Our File/N/Réf.           **50 RS 724 -1**  
Your File/V/Réf.

DATE                        19 March 1999

TO/DEST.                 Co-ordinator  
                                  Transportation Committee

FROM/EXP.                Director Engineering Division  
                                  Environment and Transportation Department

SUBJECT/OBJET           **REHABILITATION OF POOLEY'S BRIDGE AND FIVE STONE  
                                  ARCH BRIDGES - LEBRETON FLATS**

---

**DEPARTMENTAL RECOMMENDATIONS**

**That Transportation Committee recommend Council:**

- 1. Approve the rehabilitation of Pooley's Bridge as a pedestrian/bicycle facility in accordance with Alternative 3B;**
- 2. Authorize the Department to undertake necessary repairs to five other stone arch bridges in the area as noted in the report;**
- 3. Authorize filing of an 'Application to Alter' to the City Of Ottawa for modifications relating to rehabilitation of Pooley's Bridge per the recommendation (1a) above, as required under provisions of the *Ontario Heritage Act*;**
- 4. Authorize staff to undertake detailed design of the rehabilitation of Pooley's Bridge per recommendation (1a) above and repairs to five bridges over the aqueduct as outlined in recommendation (1b);**
- 5. Authorize staff to undertake necessary utility relocations for this project;**
- 6. Authorize the initiation of the public hearing process as required by Sections 297 and 300 of the *Ontario Municipal Act*.**

## EXECUTIVE SUMMARY

Pooley's Bridge and five other stone arch bridges in the Lebreton Flats area, built circa 1873, are the oldest bridges in the Region. All of these bridges are Heritage Bridges and are designated to serve as pedestrian/bicycle facilities only in the future.

The condition of Pooley's Bridge has been of concern for a number of years. It was necessary to undertake the controlled removal operations on the bridge in 1994, to ensure public safety. Further failures at this bridge are anticipated. Rehabilitation of the bridge using existing stones is not feasible.

Doing nothing is not a viable option. A delay in action to rehabilitate or stabilize the bridge may leave no other alternative except for demolition, resulting in a loss of an important heritage resource.

Twelve different alternatives in six categories were considered. The choices range from rehabilitation of the bridge as is, to a width that is sufficient for use of the facility by pedestrians and bicycles only, with variations ranging from the retention of the old structure in some stabilized form to no structure at all.

Alternative 3B, at an estimated cost of \$1,270,000 is recommended. This includes the partial preservation of the existing structure and provision of a 4.5 metre wide facility, to be constructed on the southern side of the existing structure and retaining the heritage aesthetics of the south face of the existing bridge.

The repairs required at the five stone arch bridges are relatively minor and for the most part include repointing of joints, removal and replacement of deteriorated stones, etc. For the Broad Street Bridge, removal of concrete additions added in 1935, and reinstatement of stone balustrade are proposed.

The construction operations are proposed to be undertaken in 2000, subject to budgetary approvals.

## BACKGROUND

Pooley's Bridge is a three span closed spandrel stone arch structure built in 1873. The existing structure is 37.2 metres long and 18.3 metres wide, over the channel tailrace of the Fleet Street Pumping Station. The bridge was designated as a Heritage structure by the City Of Ottawa in 1994.

The five Lebreton Flats Bridges are all single span stone arch bridges over the aqueduct, west of Pooley's Bridge. These structures were built around the same time as Pooley's Bridge and are also designated as Heritage Bridges. These bridges include: Canada Central Railway Bridge, Broad Street Bridge, Lloyd Street Bridge, Grand Trunk Railway Bridge and Lett Street Bridge. The first bridge is owned by the National Capital Commission, second, third and fifth by the City

of Ottawa and the fourth bridge is under the Region's ownership. The third, fourth and fifth bridges are connected together.

As part of the tripartite Lebreton Flats Agreement with the National Capital Commission and the City of Ottawa, the Region is committed to undertake limited repairs to the five bridges to a maximum of \$500,000 plus inflationary adjustments based on a formula included in the agreement, in part exchange for acquisition of certain lands for transit purposes.

On 13 May 1997, Planning and Environment Committee approved the following recommendation as part of the consideration of Regional Official Plan Amendment (approved by Regional Council on 09 July 1997).

*“ That Pooley’s Bridge be rehabilitated as a pedestrian and bicycle facility.”*

On 04 August 1998, Corporate Services and Economic Development Committee approved the appointment of Stantec Consulting Group, with Barry Padolsky, Heritage Architect, as sub-consultant, to provide engineering services to reassess the condition and feasibility of rehabilitation of Pooley's Bridge as a pedestrian/bicycle facility. This reassessment was initiated due to heritage interest in the structure. The engineering reports completed in 1994 indicated that the structure could not be economically rehabilitated due to concerns relating to continuing disintegration of the existing stones. This appointment also included engineering services related to limited repairs to five single span stone arch bridges in the Lebreton Flats area. The locations of Pooley's Bridge and five Lebreton flats Bridges are illustrated in Figure 1.

### POOLEY'S BRIDGE

Since 1983, Pooley's Bridge has been restricted to pedestrian/bicycle use only. This is also the designated function for this crossing for future use per the current Regional Official Plan. The bridge is also part of the Regional Cycling Network.

North of the structure, the channel tailrace is used as a training facility by kayakers. Along the east shore of the tailrace, there is an existing asphalt pathway, extending under the east arch of the bridge and continuing westwards along the southern limits of Pooley's Bridge. This pathway has been closed since 1981, due to the erection of a shoring system to support the east arch of the bridge. Fleet Street Pumping Station, a restored historic structure, is located just south of the Pooley's Bridge.

The deteriorating condition of the Pooley's Bridge has been a continuing source of concern.

### CONDITION REASSESSMENT

A detailed on-site investigation of the condition of Pooley's Bridge was undertaken during the fall of 1998 and the results were compared with previous condition inspections undertaken in 1994. The structure continues to deteriorate progressively with fractured stones at arches and new areas

of concern at the south end of both piers, threatening the support of the south spandrel wall. The spandrel wall is a structural fascia wall intended to support fill on arches.

It should be noted that, during 1994, it was necessary to undertake the controlled removal operations of the north spandrel wall due to similar concerns. The south retaining wall, immediately west of the existing structure, is tilting and could fail at any time. A large portion of this wall failed in 1981.

As part of the reassessment of the condition of the bridge, Mr. Keith Blades, a historic masonry stone restoration specialist, was retained to undertake an independent review of the condition of the stones to update his 1994 report. This report confirms that the surface of the stones continues to fracture and any remedial work to individual stones would require complete replacement of the same.

The main reason for deteriorated condition of Pooley's Bridge are the stone units used in original construction. These stones are inferior limestone susceptible to micro cracking through freeze/thaw action and salt growth in the microstructure. This results in crumbling of stones as any reworking is attempted. This limits options with respect to rehabilitation and requires replacement of the existing stones, if the same are to serve structural function for an extended period of time. It should be noted that during the controlled removal operations undertaken in 1994, it was possible to recover only about 5% of the original stone units.

In comparison, the stones used for the other six bridges in the same area are of much better quality. At Parliament Hill, the stones used are of good quality sandstone which does not exhibit the same form of cracking as limestone. Any cracking in the stones at Parliament Hill is as a result of structural movement as opposed to weathering.

### TRAFFIC CONDITIONS

An interpolation of the 1996 traffic data taken at Booth/Fleet Street and Booth/Eddy intersections indicate a conservative estimate of about 200 bicycles during PM peak hours at Pooley's Bridge.

These volumes, assuming redevelopment of the Lebreton Flats area, during PM peak hours have been projected to increase to the following volume range, per analysis undertaken by the Planning and Development Approvals Department:

<u>Year</u>	<u>Projected PM Peak Hour Volume Range</u>
2005	275 to 400
2015	300 to 425
2021	325 to 450

## DEVELOPMENT OF ALTERNATIVES

The following factors were taken into consideration with respect to development of alternatives for Pooley's Bridge:

- Safety of all users, on and under the bridge;
- The future designated function of the bridge as a pedestrian-bicycle facility;
- Historic significance of the bridge, aqueduct, tailrace and Fleet Street Pumping Station;
- Proposed redevelopment of Lebreton Flats area, including opportunities for additional pedestrian and bikeway facilities across the tailrace;
- Opportunities for opening up the lower pathway, closed since 1981, following rehabilitation/reconstruction of Pooley's Bridge;
- Existing crossing is part of the Regional Cycling Network;
- Kayaking in the tailrace and other recreational uses in the area.

The 'do nothing' alternative is not practical due to public safety concerns, Fleet Street Pumping Station operations and Heritage considerations. In the event of a sudden collapse of the bridge, the tailrace may be blocked and it will be necessary to implement emergency contingency measures, including temporary shut-down of the pumping station.

The Fleet Street Pumping Station provides about \$2,000 in electrical savings each day that it functions. In case of a temporary shut-down, the additional cost will be much higher due to the penalty associated with peaking of hydro loads.

Twelve different alternatives in six categories, from rehabilitation of the bridge as is, to a width that is sufficient for the intended functional use (pedestrians and bicycles only), with variations in the retention of the old structure in some stabilized form to no structure at all at this crossing were considered. From the outset, it was evident that the rehabilitation of the structure using existing stones was not feasible due to the condition of existing stones.

Alternative 1 is based on rehabilitation of the bridge to full width of the existing structure (18.0 metre total and 16.7 metre clear).

Alternatives in categories 2 to 5 were initially developed on the basis of a 5.0 metre wide structure with a 3.8 metre usable width and were presented as such at the Public Information Centre. These alternatives have since been revised to provide a 4.5 metre clear usable width. There is progressively lesser preservation of heritage elements from alternatives 2 to 5.

Alternative 6 envisages removal of the structure altogether.

The alternatives are summarized as follows:

**Alternative 1:** Rehabilitation to existing width with new elements. (Fig. 3)

Apart from providing a 16 m. width, Alternative 1 would recreate the aesthetics of the original bridge with a substantial quantity of new stones using an inner concrete support structure. The historic character of the



pump house forecourt as well as the completeness of the original aqueduct/waterworks infrastructure, are retained.

On the negative side, there is high initial capital cost as well as high maintenance costs due to safety concerns resulting from continued scaling of retained stones from original construction.

Estimated cost of this alternative is \$4,350,000 with a 50 year service life, with a major rehabilitation in a 25 year timeframe.

**Alternative 2A:** Rehabilitation to accommodate new bridge on south side and maximum retained ruin elsewhere. (Figs. 4 & 5)

Estimated cost of this alternative is \$1,600,000 with a 50 year service life.

**Alternative 2B:** Rehabilitation to accommodate new bridge on north side and maximum retained ruin elsewhere. (Fig. 6)

Estimated cost of this alternative is \$1,490,000 with a service life of 50 years.

Category 2 alternatives retain a significant part of the existing historic fabric as a functional component or ruin. Also, the historic character of the pump house forecourt is retained. As well, the original aqueduct/waterworks infrastructure is retained though to a lesser extent than in Alternative 1. Under Alternative 2A, the south face is restored to original aesthetics.

On the negative side, there are concerns with respect to security and safety as it may not be completely possible to prevent unauthorized access to the top of the arches.

Also, there are high maintenance costs similar to those for Alternative 1.

**Alternative 3A:** Rehabilitation to accommodate a new concrete bridge on the south side and 'Ghosted' outline of south spandrel wall. (Fig. 7)

Estimated cost of this alternative is \$1,300,000 with a service life of 50 years.

**Alternative 3B:** Rehabilitation to accommodate a new concrete bridge on south side and preservation of substructure elements. (Fig. 8)

Estimated cost of this alternative is \$1,270,000 with a service life of 50 years.

**Alternative 3C:** Rehabilitation to accommodate a new bridge on south side and preserve pier elements. (Fig. 9)

Estimated cost of this alternative is \$1,280,000 with a service life of 50 years.

Under alternatives in this category, all but south five meters of the arches are removed but the piers are retained as supports for the new bridge or are preserved as ruins outside the five meter limit.

On the negative side, there is lesser conservation of the historic fabric as compared to alternatives in Categories 1 and 2. Safety and maintenance concerns remain though to a lesser degree.

**Alternative 4A:** New 3 span concrete arch bridge (centred) on existing substructure. (Fig. 10)

Estimated cost of this alternative is \$1,300,000 with a service life of 50 years.

**Alternative 4B:** New 3 span steel arch bridge (centred) on existing substructure width. (Fig. 11)

Estimated cost of this alternative is \$1,050,000 with a service life of 50 years.

**Alternative 4C:** New single span concrete arch structure (centred) on existing substructure. (Fig. 12)

Estimated cost of this alternative is \$1,025,000 with a service life of 50 years.

Under Category 4 alternatives, preservation of the historic fabric is limited to substructure components only, however, there are lower long term maintenance costs.

**Alternative 5A:** New 3 span contrasting bridge. (Fig. 13)

Estimated cost of this alternative is \$1,010,000 with a service life of 50 years.

**Alternative 5B:** New 5 span steel bridge. (Fig. 14)

Estimated cost of this alternative is \$700,000 with a service life of 50 years.

Under this category of alternatives, there is minimal or no conservation of the historic fabric and a part of the original aqueduct/waterworks infrastructure is eliminated. Initial capital costs and future maintenance costs are lower.

**Alternative 6:** Remove structure including piers, preserve existing substructure as ruins and use lower access road. (Fig. 15)

This alternative provides a lower level linkage only, with a concrete staircase at the northeast corner of the existing structure. Existing bridge level access is eliminated. This alternative takes the users closer to the tailrace level and the Fleet Street Pumping Station. Due to the removal of the bridge, the sight distances at pathway under the east arch are improved. However, the grades at the west end of the lower pathway are steep and it will be necessary to provide alternate access for those physically challenged. Also there are safety and security concerns of users due to the pathway being hidden from view.

It will also be necessary to install security fencing for the pumping station.

Under this alternative include permanent construction of the proposed temporary pedestrian and bicycle detours, illustrated in Fig. 2, has been assumed.

Estimated cost of this alternative is \$670,000.

All of the costs indicated above are ‘Order of Magnitude’ costs only and are intended to be used for the purpose of comparison of various alternatives. The costs may change due to variation in scope of intended works during the detailed design stage as a result of input from various stakeholders.

The above costs also include a temporary detour during construction using the old Wellington Street right-of-way and Lloyd Street, Grand Trunk and Lett Street Bridges for bicycles, pedestrians and physically challenged persons. For Alternative 6, costs for permanent retention of this detour are included. (Fig. 2)

### LOWER PATHWAY

For Alternatives 1, 2A & 2B, it will be necessary to install overhead protective measures for protection of the users of the lower pathway as there is still a possibility of falling disintegrated stones. Similar protective measures are also needed where parts of the old structure are retained under Category 3 and 4 alternatives, though to a lesser degree.

Although it is possible to open the lower pathway under all alternatives, there are serious concerns with respect to the security of the Fleet Street Pumping Station if the lower pathway is

opened up. There have been recent incidents of vandalism. It may be necessary to install fencing to secure the pumping station at the south limit of the lower pathway.

### EXISTING UTILITIES

Existing utilities include active duct banks owned by Ottawa Hydro and Bell Canada. These utilities will have to be supported during construction under alternatives in Categories 1 to 5 and relocated under Alternative 6. There are also abandoned gas main and water service pipes within the existing structure.

### TAILRACE AND KAYAKING FACILITIES

The tailrace north of Pooley's Bridge is a designated heritage facility and a Class 1 Fish Habitat. It is also considered to be a World Class Olympic training facility by local kayaking groups. At present, the southerly limit of the facility is about 20 m north of the bridge. This limit is presently governed by the condition of the bridge itself.

Kayaking groups have indicated a preference for extending these facilities southwards to limits under the bridge. To ensure safety of the kayakers, it is essential that kayaking activities be limited to outside the active hydraulic zone of the Fleet Street Pumping Station facility. A review of the hydraulic conditions has been undertaken by the Water Division to determine safe limits for kayaking purposes. Based on this review, extension of kayaking limits southwards is definitely not recommended.

### EVALUATION OF ALTERNATIVES FOR POOLEY'S BRIDGE

An Evaluation Matrix was developed to assess the alternatives developed. This evaluation matrix included assignment of 40 % weighting to each of Functional and Heritage group of issues and 20 % for cost related issues including initial capital costs and long term maintenance costs. This matrix was intended to provide a uniform way of assessing the alternatives under consideration.

An assessment of various alternatives by the Project Team is as follows:

#### POOLEY'S BRIDGE: EVALUATION MATRIX

Criteria Evaluation	Alternatives											
	1	2A	2B	3A	3B	3C	4A	4B	4C	5A	5B	6
<b>Function: (40)</b> Pedestrian/bicycle use Kayaking/recreational uses Safety & security of users Other	35	35	35	40	40	40	40	40	40	40	40	15
<b>Heritage: (40)</b> Preservation of heritage elements Historic Fabric Aesthetics Compatibility with Aqueduct/Water Works Structure Other	40	35	35	33	33	30	15	15	15	15	0	5
<b>Cost: (20)</b> Initial capital cost Long term maintenance cost	0	8	10	11	13	13	12	14	15	15	18	20
<b>Total Points</b>	<b>75</b>	<b>78</b>	<b>80</b>	<b>84</b>	<b>86</b>	<b>83</b>	<b>67</b>	<b>69</b>	<b>70</b>	<b>70</b>	<b>58</b>	<b>40</b>

#### CONSULTATION

A 'Pooley's Bridge Advisory Committee' was formed to seek stakeholder input. This Committee included representatives from bicycle and pedestrian groups, Dalhousie and Centretown Community Associations, Heritage groups, Ottawa River Runners Kayak Club, City and Regional Ward Councillors, City of Ottawa, National Capital Commission, Consultants and staff. A meeting of the Advisory Committee was held on 12 November 1998.

This Committee was also requested to rate various alternatives based on the Evaluation Matrix developed for this project, via email, fax or normal mail. Seven responses were received.

On 16 November 1998, a Public Information Session was held at St. Luke's Church on Somerset Street. This session was attended by about 40 individuals and 26 comment sheets have been returned to date.

Based on the comments received from various individuals and those completing the Evaluation Matrix, there is no clear preference for any particular alternative.

## LOCAL ARCHITECTURAL CONSERVATION ADVISORY COMMITTEE (LACAC) COMMENTS

On 17 November 1998, a presentation was made to City of Ottawa's Local Architectural Conservation Advisory Committee (LACAC). The following motion was passed at its meeting on 17 December 1998:

### Quote

*"LACAC resolves that the best possible option for Pooley's Bridge is the first one, the preservation of the existing historic structure which is both Ottawa's oldest bridge and a designated heritage structure. LACAC urges a reconsideration of the bridge with an approach that considers, as well, as the concept of a partial restoration, a stabilized ruin."*

1. *A solution which would not preclude additional restoration or reconstruction in the future, if funds permit.*
2. *The retention of a structural conservator to provide appropriate solutions to the structure and its historic facilities, including the technology of stone structure stabilization.*

### Unquote

In a letter dated 26 January 1999, Mr. Robert Pajot of LACAC advised that the proposed Evaluation Matrix will not be completed on behalf of that agency.

LACAC has also undertaken a public awareness initiative with respect to the heritage significance of this bridge during talks to children in one of the local schools.

## HERITAGE DESIGNATION IMPACT

In 1994, City of Ottawa approved Heritage Designation for Pooley's Bridge under the *Ontario Heritage Act*. Per the provisions of this act, permission of the City of Ottawa Council is required prior to taking any steps to alter or demolish. Based on information available from City of Ottawa staff a formal 'Application to Alter' would be required under all alternatives except Alternative 1.

A report will be brought forward to the Transportation Committee, in case an alternative approved by the Regional Council is not endorsed by the City of Ottawa.

## RCAG COMMENTS

On 01 December 1998, a presentation was made to the Regional Cycling Advisory Group. The following resolution was passed at this meeting:

*“that a structure be provided with at least a minimum usable deck width of 4.5 m to accommodate both pedestrians and cyclists”*

## CONCLUSIONS

Based on Condition Surveys completed in 1998 and comparing these to earlier surveys, it is evident that progressive deterioration of the structure is continuing. Further failures are possible at any time. Rehabilitation of the structure using existing stone units is not feasible.

The existing bridge width is not needed for the intended future functional use of the bridge as a pedestrian/cycling facility only. The bridge was originally designed to accommodate four lanes of traffic.

Based on assessment of various alternatives developed, implementation of Alternative 3B is recommended. The main features of this alternative are as follows:

- Construction of a new concrete structure with stone veneer, with a clear usable width 4.5 metres, constructed at southern limits of the existing structure, with retention and stabilization of south spandrel wall;
- New railing on north side with stone veneer;
- Existing piers are retained and stabilized as ruins;
- Existing arches are removed, except for the south five metres;
- Low to medium maintenance costs;
- Heritage appearance of the south elevation of the existing structure is retained, which is considered to be a prominent feature;
- Heritage Character of the Pumping Station forecourt is retained;
- Functional needs of all users are accommodated.

## LEBRETON FLATS BRIDGES

The repairs required at five stone arch bridges are relatively minor and these for the most part include repointing of joints, removal and replacement of deteriorated stones, etc. For Broad Street Bridge (owned by City of Ottawa), removal of concrete additions (added circa 1935) and deck and reinstatement of stone parapet/balustrade above the sidewalk are included.

These bridges, though built at about the same time as Pooley’s Bridge, are in much better condition, mainly due to the quality of stones used in original construction.

The intended function of these bridges, per the Lebreton Flats Redevelopment Plan, is for pedestrian/ bicycle use only.

These repairs can be completed within the financial limits of \$500,000 plus adjustments, per the Lebreton Flats Development Agreement.

### FINANCIAL IMPLICATIONS

The current funding provisions for Pooley's Bridge Rehabilitation were established in 1995 at \$450,000 and were based on Minimum Intervention Alternatives with a service life of five years or so. This funding is insufficient to undertake construction activities in 1999.

In view of the Heritage Designation of the Bridge and approvals required from City of Ottawa and other agencies, implementation of construction activities in 1999 would be impractical.

Necessary supplementary financial authorities for completion of the project will be requested in the year 2000 Capital Budget, based on the alternative approved by the Regional Council.

*Approved by  
J. Miller, P. Eng.*

VKS/WG/ac



**POOLEY'S BRIDGE AND  
LEBRETON FLATS BRIDGES  
LOCATION PLAN**

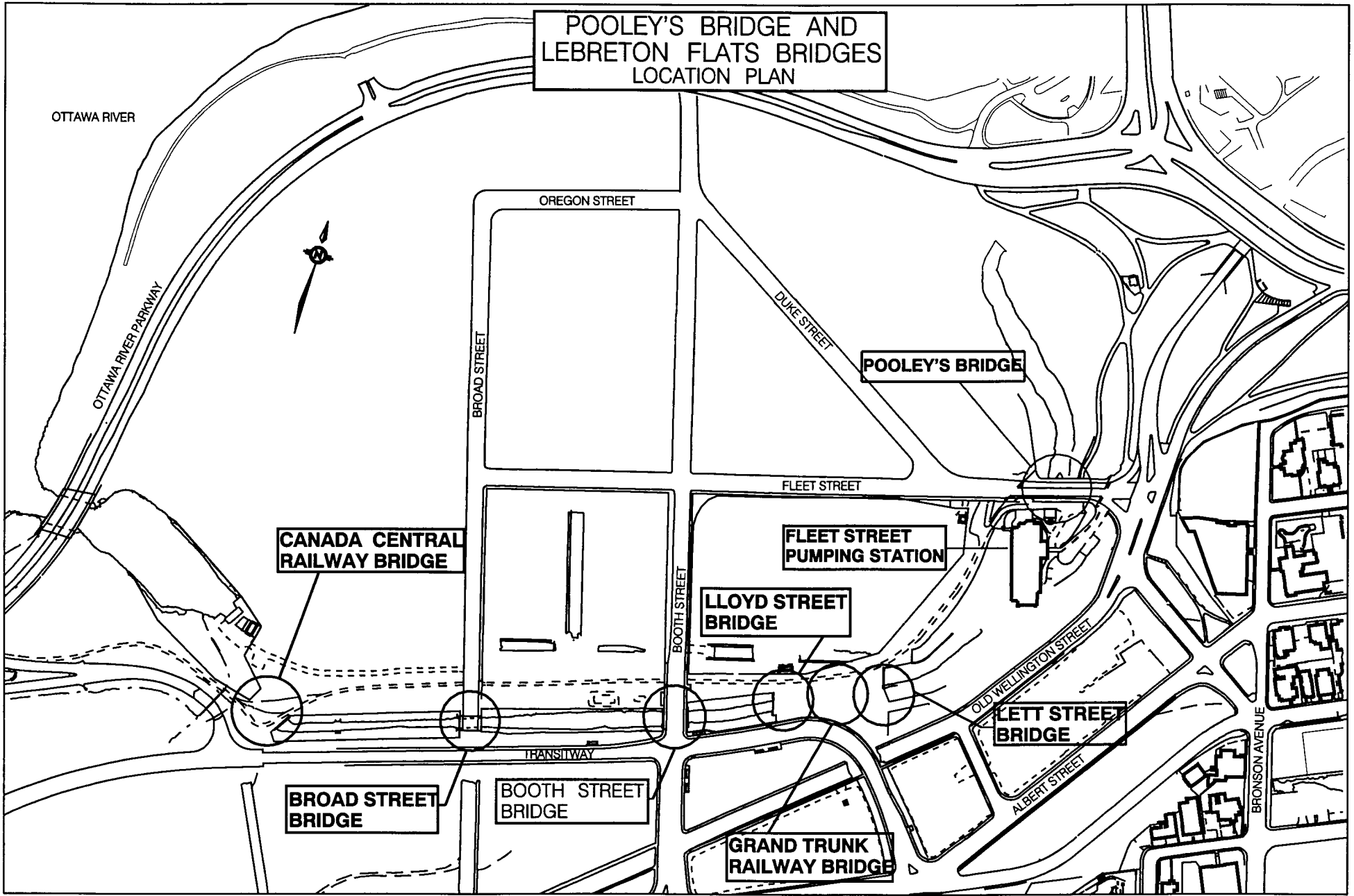

**FIG 1**

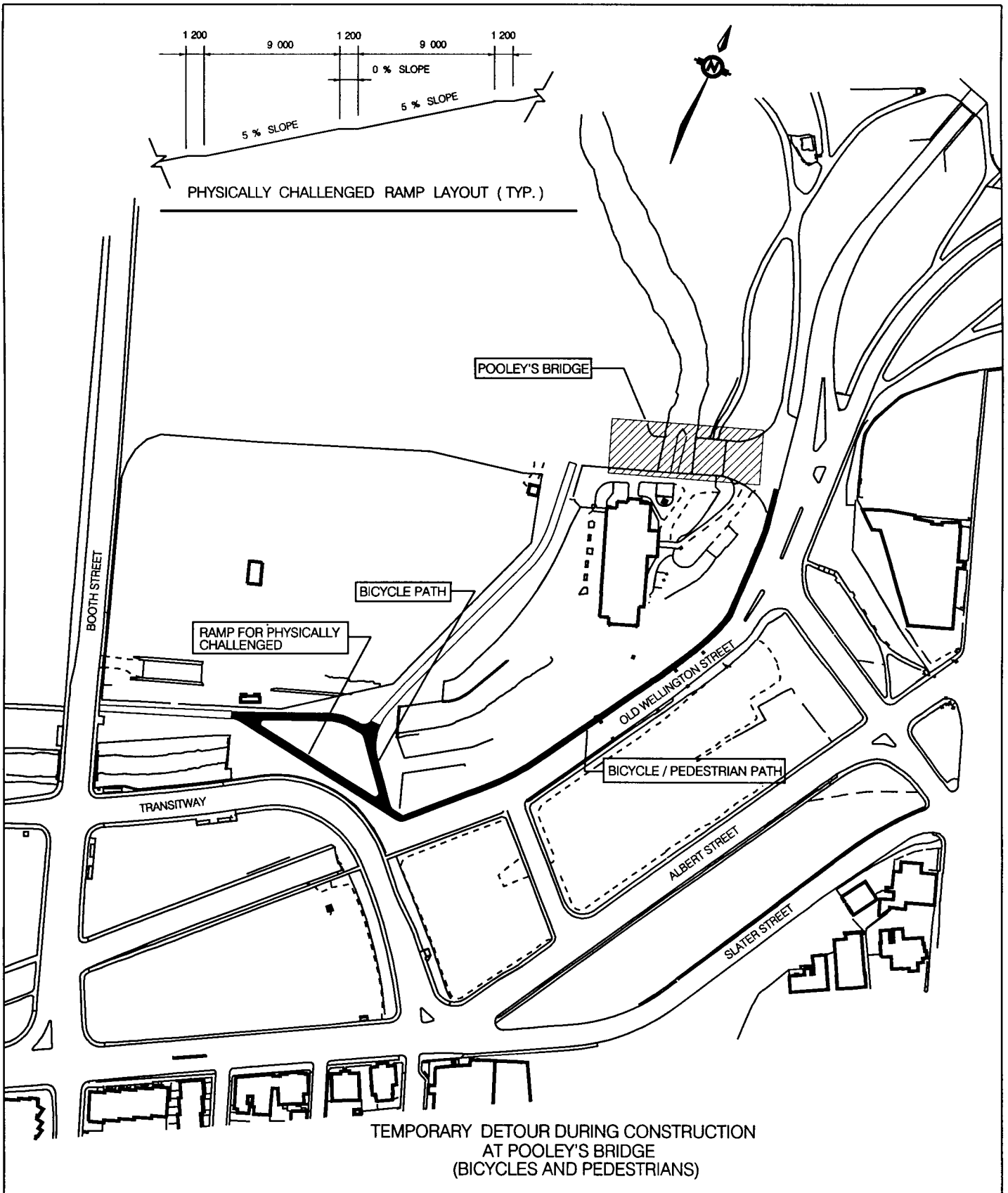
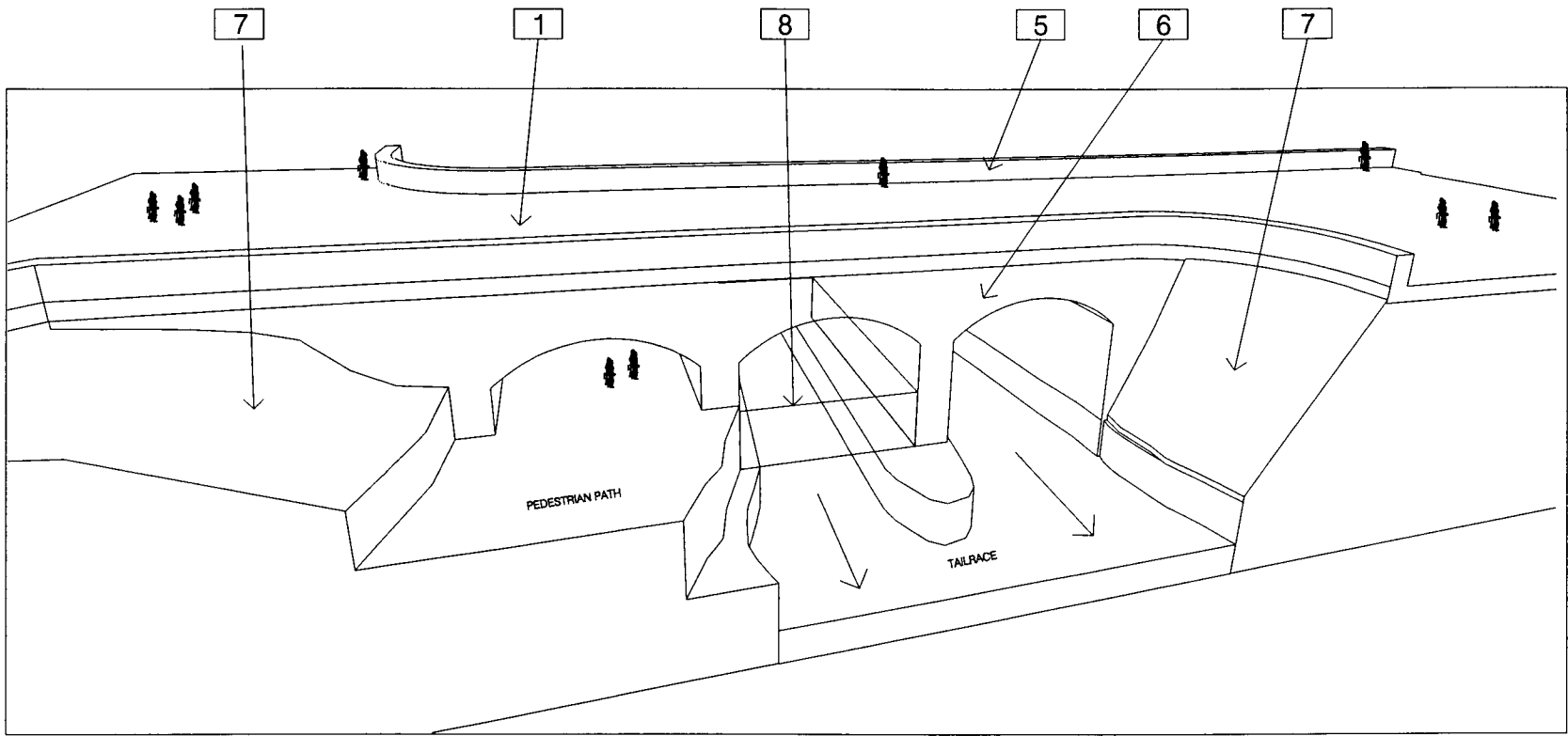
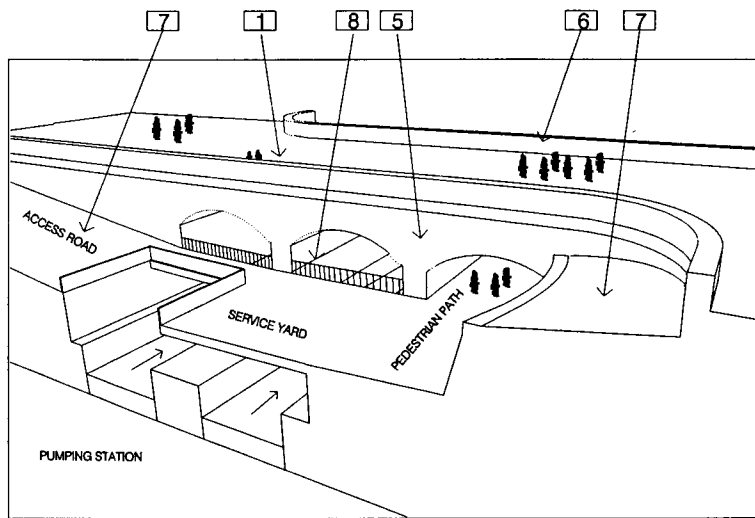

FIG 2



PERSPECTIVE VIEW FROM NORTH



PERSPECTIVE VIEW FROM SOUTH

Drawing Legend:

- 1. Rehabilitated bridge.
- 2. New concrete arches.
- 3. New concrete slab and upstand.
- 4. New fill.
- 5. Refaced stone south spandrel wall.
- 6. New stone north spandrel wall.
- 7. Landscaping to remain.
- 8. Remove existing timber cribwork.

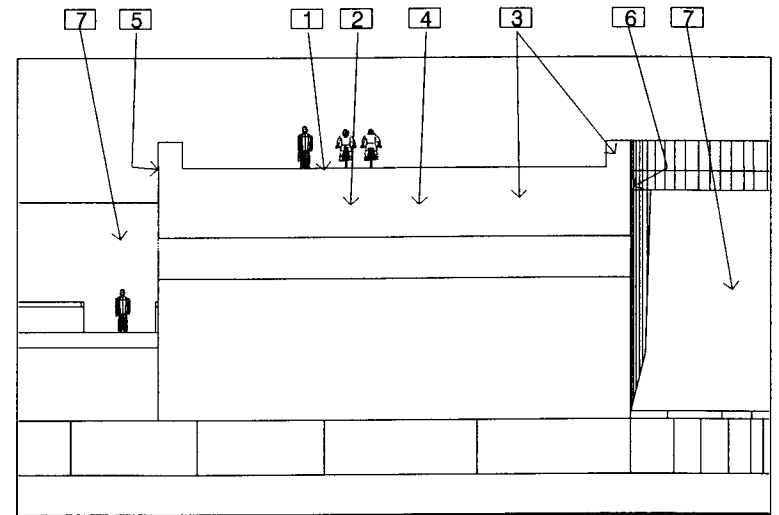

SECTION LOOKING WEST

POOLEY'S BRIDGE REHABILITATION ALT. 1

FIG 3

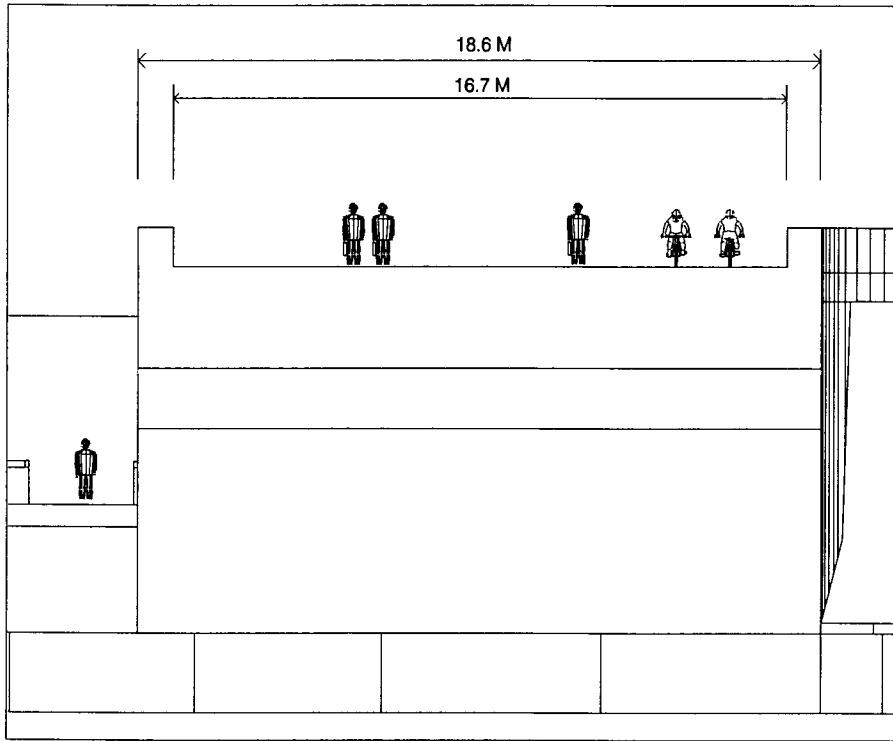

CROSS SECTION - ALTERNATIVE 1

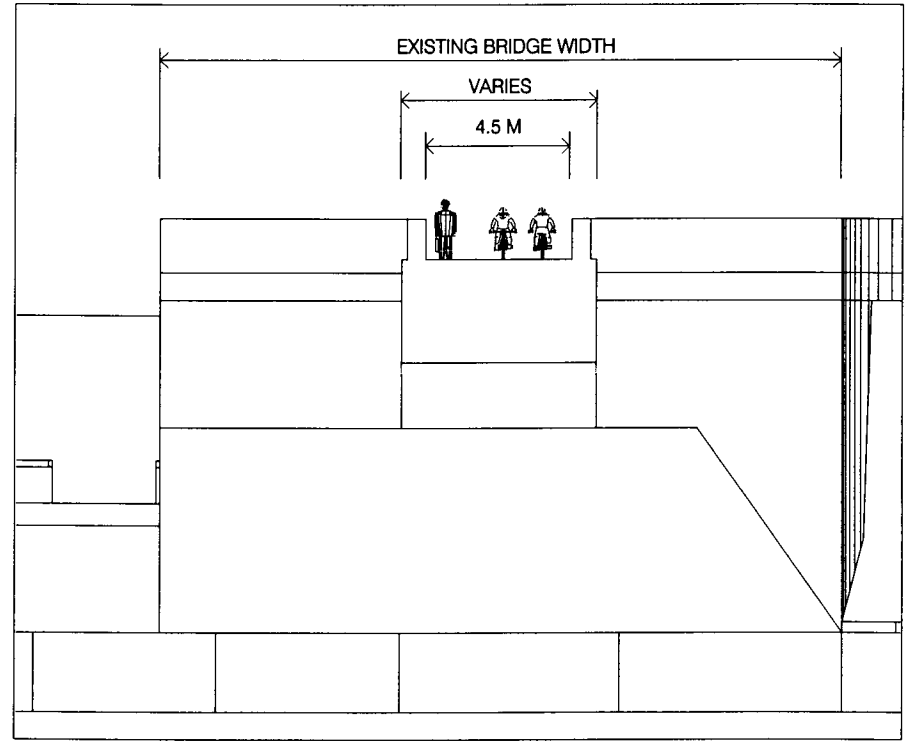

CROSS SECTION - ALTERNATIVES 2 to 5

## BRIDGE DIMENSIONS

POOLEY'S BRIDGE REHABILITATION ALT. 2A

FIG 4

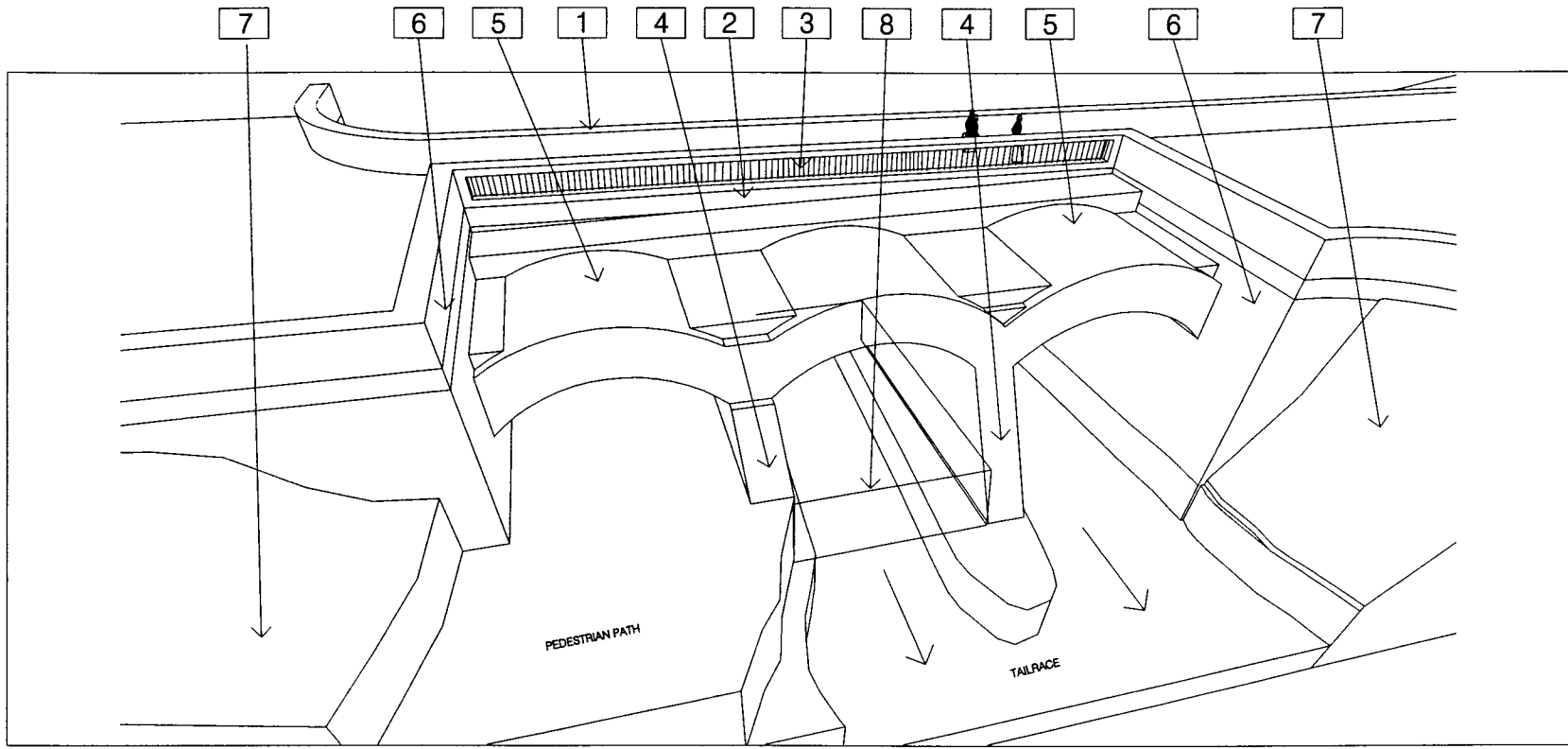

PERSPECTIVE VIEW FROM NORTH

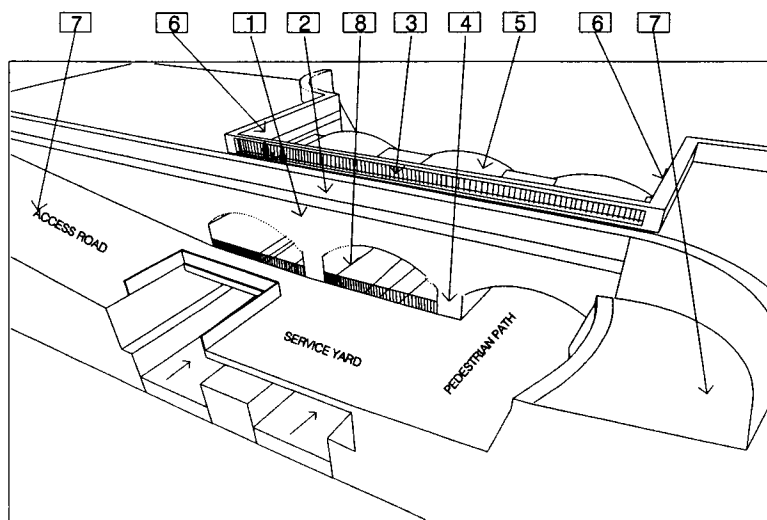

PERSPECTIVE VIEW FROM SOUTH

Drawing Legend:

- 1. Retain and stabilize existing south stone spandrel wall.
- 2. New concrete pedestrian bridge structure (stone veneer).
- 3. New north railing (stone veneer w/ metal railing).
- 4. Retain and stabilize existing stone piers as "ruins".
- 5. Retain and stabilize existing arches as "ruin".
- 6. Retain and stabilize east and west abutments north of new pedestrian bridge.
- 7. Landscaping to remain.
- 8. Remove existing timber cribwork.

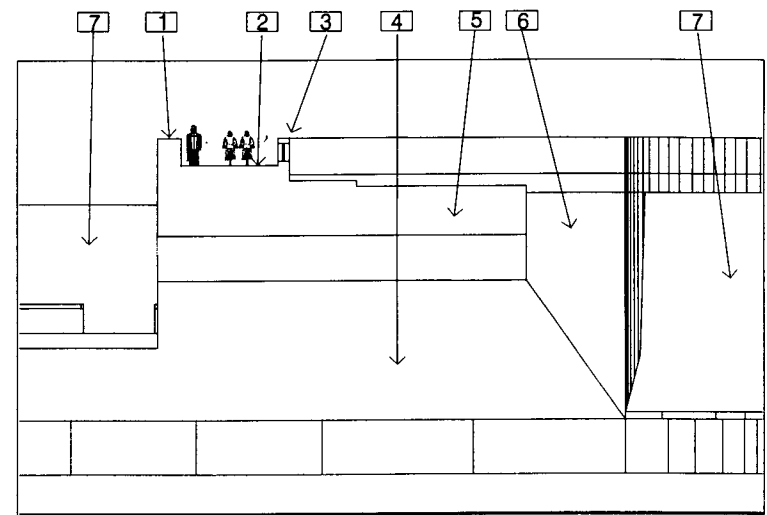

SECTION LOOKING WEST

POOLEY'S BRIDGE REHABILITATION ALT. 2A

FIG 5

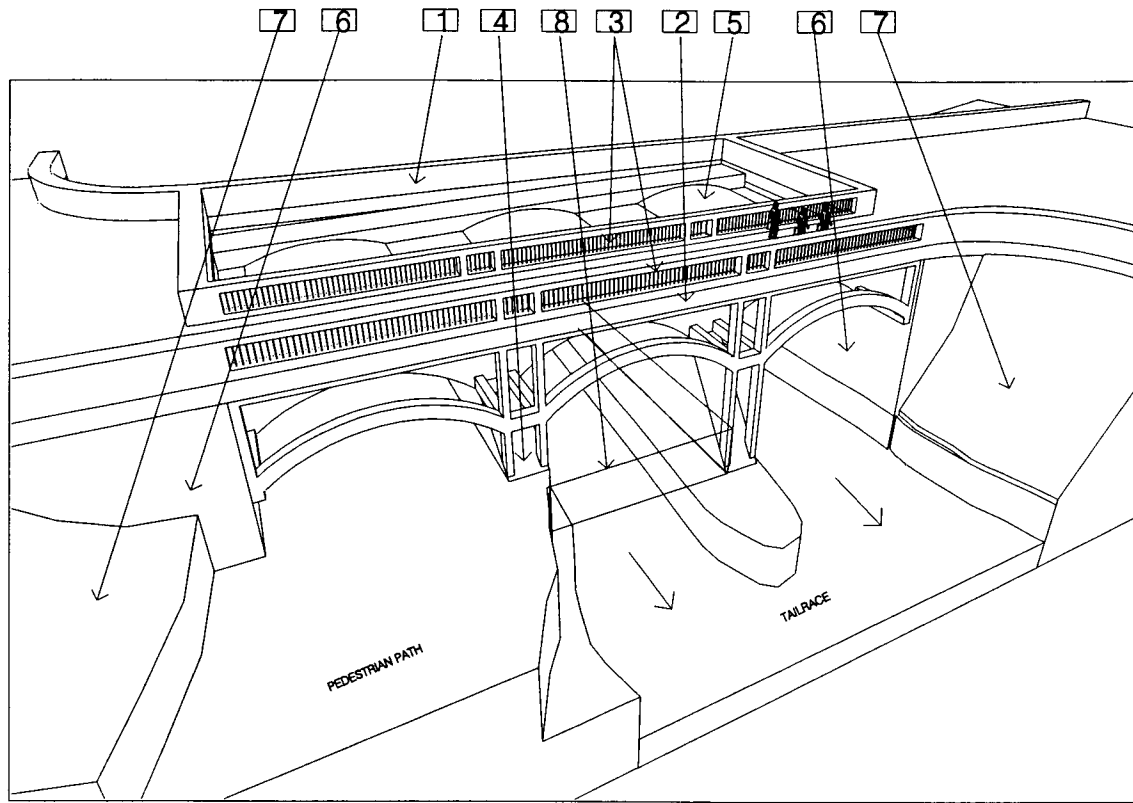

PERSPECTIVE VIEW FROM NORTH

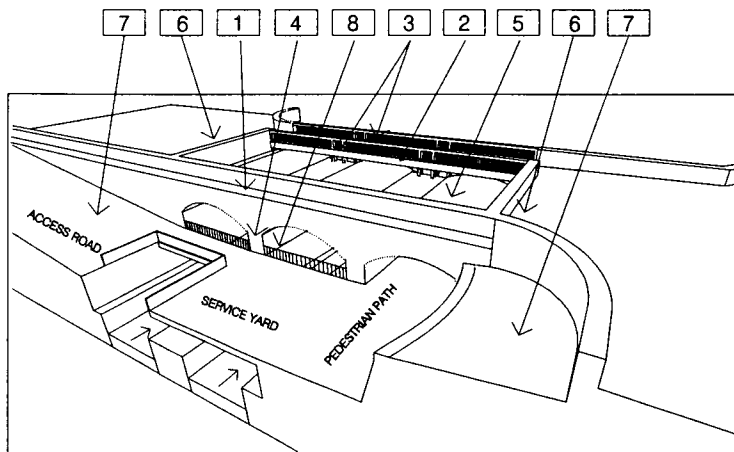

PERSPECTIVE VIEW FROM SOUTH

Drawing Legend:

1. Retain and stabilize existing south stone spandrel wall.
2. New concrete or metal pedestrian bridge structure.
3. New railings.
4. Retain and stabilize existing stone piers as "ruins".
5. Retain and stabilize existing arches as "ruins".
6. Retain and stabilize east and west abutments south of new pedestrian bridge.
7. Landscaping to remain.
8. Remove existing timber cribwork.

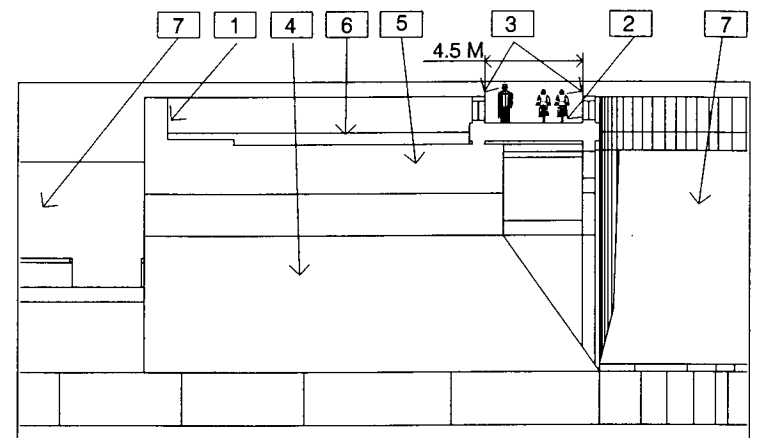

SECTION LOOKING WEST

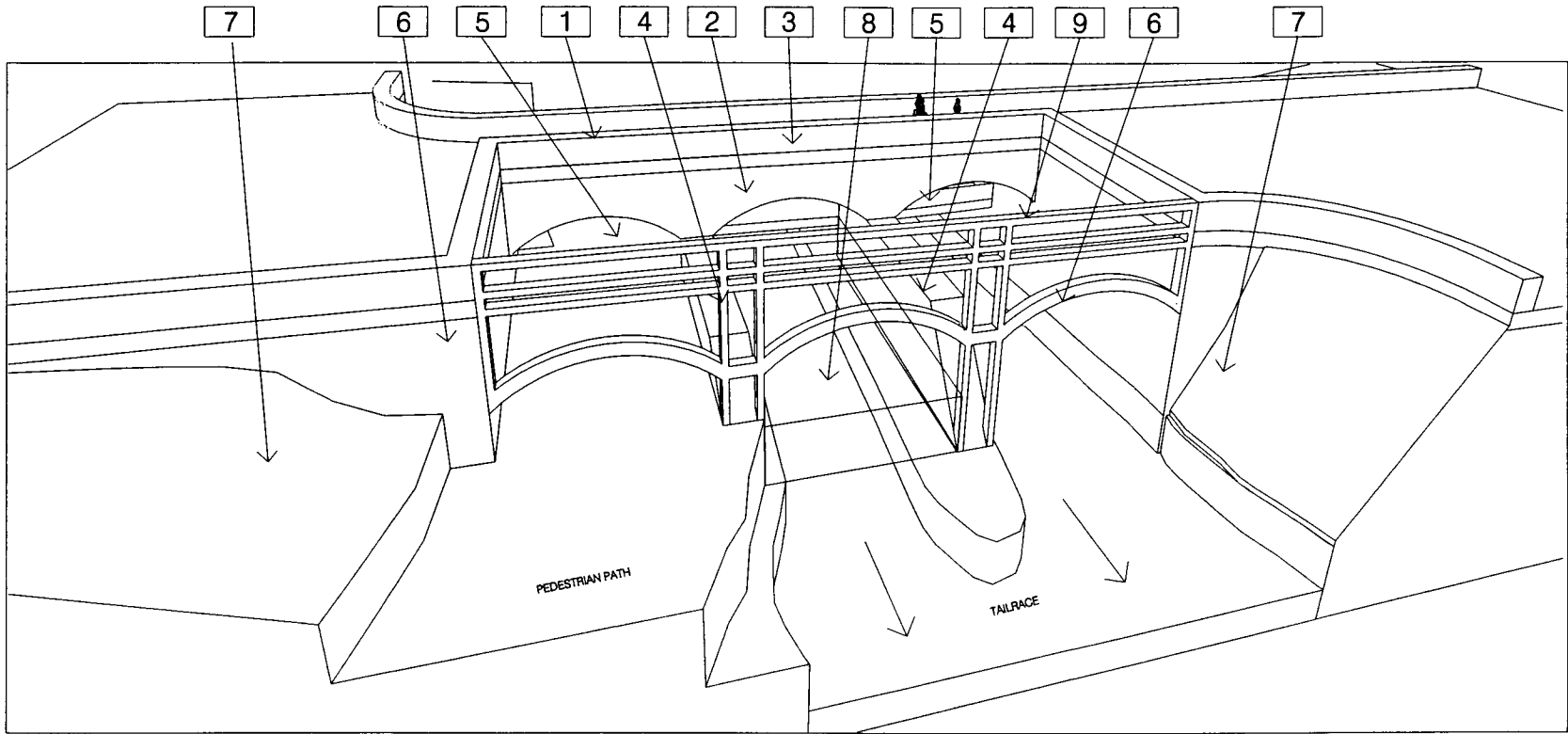

PERSPECTIVE VIEW FROM NORTH

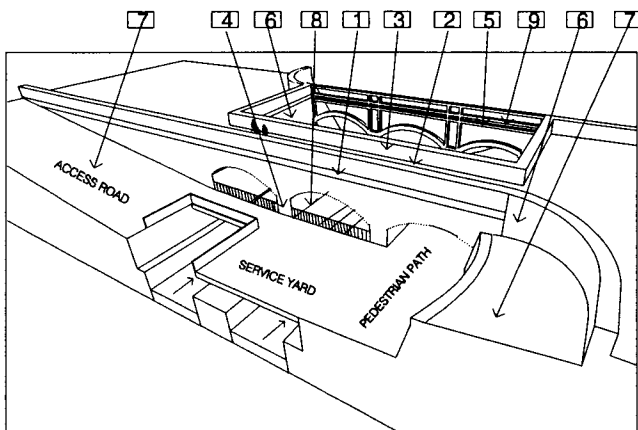

PERSPECTIVE VIEW FROM SOUTH

Drawing Legend:

1. Retain and stabilize existing south stone spandrel wall.
2. New concrete pedestrian bridge structure (stone veneer).
3. New north railing (stone veneer).
4. Retain and stabilize existing stone piers as "ruins".
5. Remove existing arches.
6. Retain and stabilize east and west abutments north of new pedestrian bridge.
7. Landscaping to remain.
8. Remove existing timber cribwork.
9. Steel "Ghost" outline of original bridge structure.

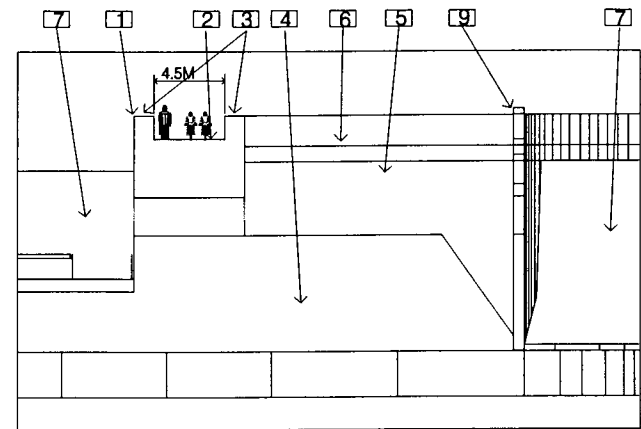

SECTION LOOKING WEST

POOLEY'S BRIDGE REHABILITATION ALT. 3A

FIG 7

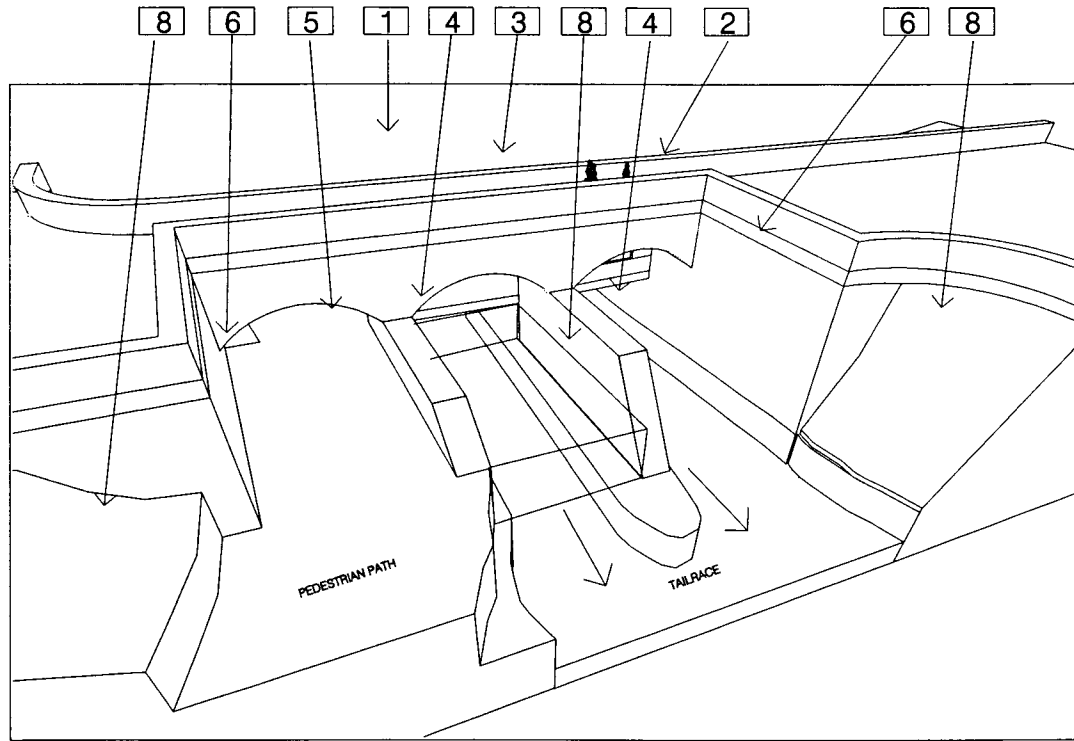

PERSPECTIVE VIEW FROM NORTH

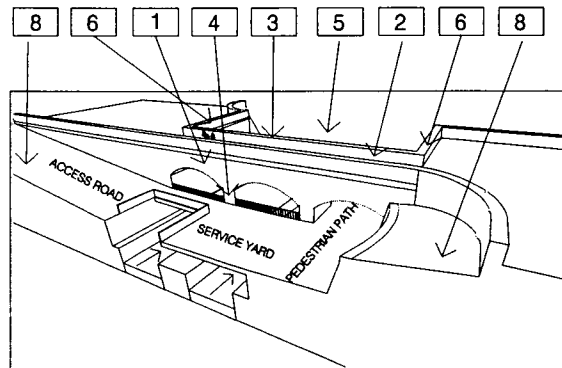

PERSPECTIVE VIEW FROM SOUTH

Drawing Legend:

1. Retain and stabilize existing south stone spandrel wall.
2. New concrete pedestrian bridge structure (stone veneer).
3. New north railing (stone veneer).
4. Retain and stabilize existing stone piers as "ruins".
5. Remove existing arches.
6. Retain and stabilize east and west abutments north of new pedestrian bridge.
7. Remove east and west abutments north of new pedestrian bridge.
8. Landscaping to remain.
9. New site regrading and new landscaping for abutment replacement.
10. Remove existing timber cribwork.

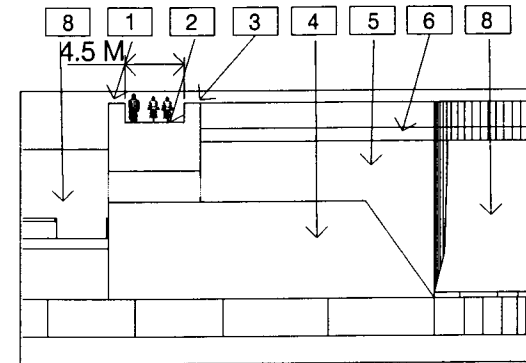

SECTION LOOKING WEST

**POOLEY'S BRIDGE REHABILITATION ALT. 3B  
(RECOMMENDED)**

**FIG 8**



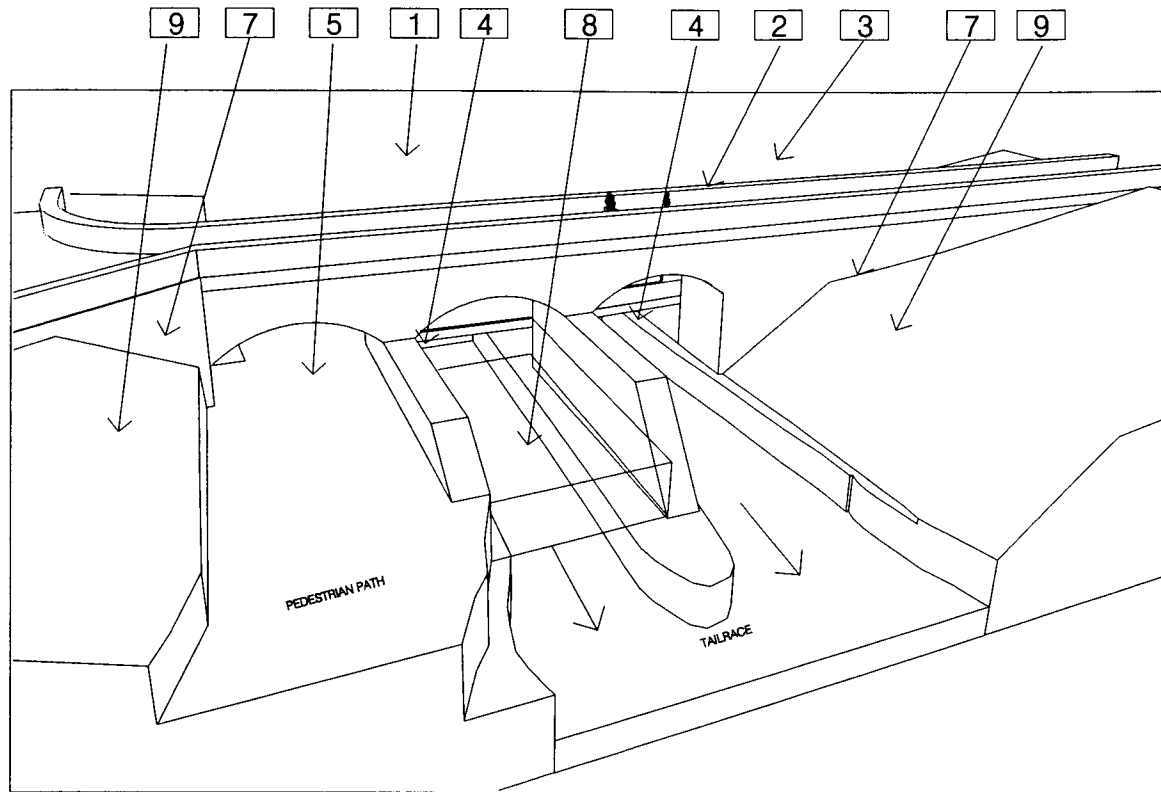

PERSPECTIVE VIEW FROM NORTH

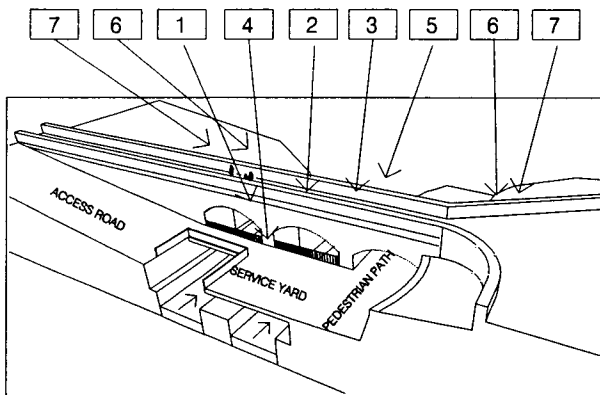

PERSPECTIVE VIEW FROM SOUTH

Drawing Legend:

1. Retain and stabilize existing south stone spandrel wall.
2. New concrete pedestrian bridge structure (stone veneer).
3. New north railing (stone veneer).
4. Retain and stabilize existing stone piers as "ruins".
5. Remove existing arches.
6. Retain and stabilize east and west abutments north of new pedestrian bridge.
7. Remove east and west abutments north of new pedestrian bridge.
8. Landscaping to remain.
9. New site regrading and new landscaping for abutment replacement.
10. Remove existing timber cribwork.

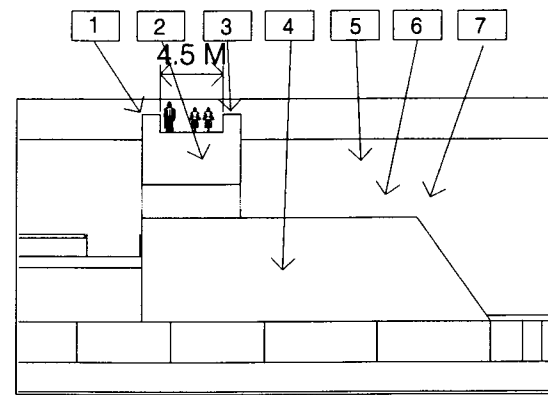

SECTION LOOKING WEST

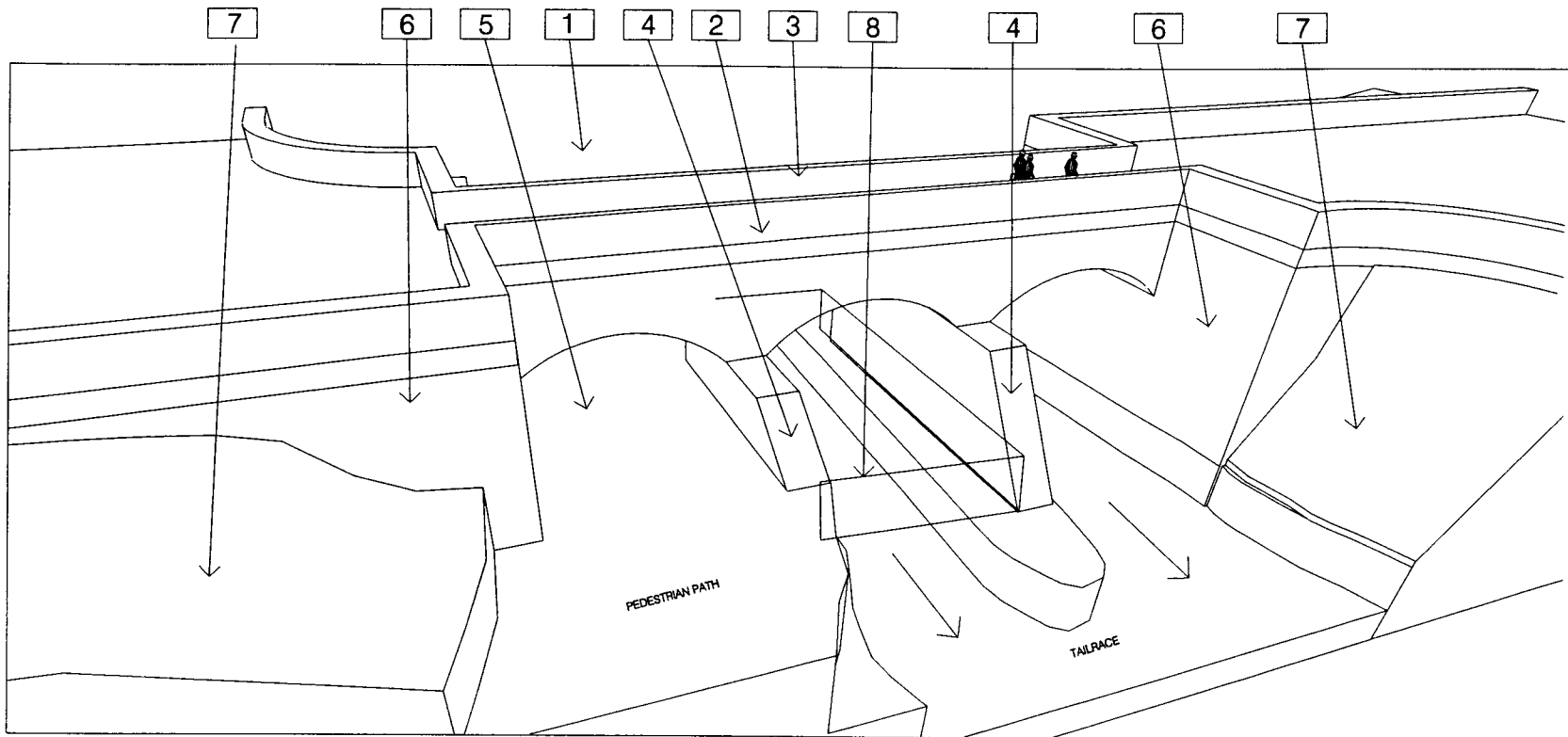

PERSPECTIVE VIEW FROM NORTH

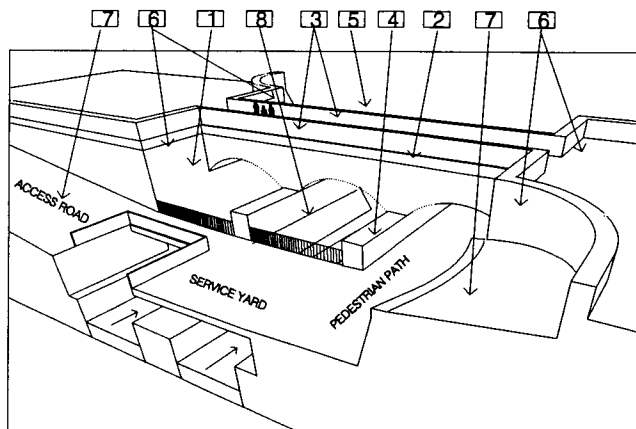

PERSPECTIVE VIEW FROM SOUTH

Drawing Legend:

1. Remove existing south stone spandrel wall between abutments. Restore the rest of the wall.
2. New pedestrian bridge structure (concrete clad with stone veneer).
3. Concrete clad with stone veneer railing.
4. Retain and stabilize existing stone piers.
5. Remove deteriorated portion of bridge.
6. Retain and stabilize east and west abutments on both sides of new pedestrian bridge.
7. Landscaping to remain.
8. Remove existing timber cribwork.

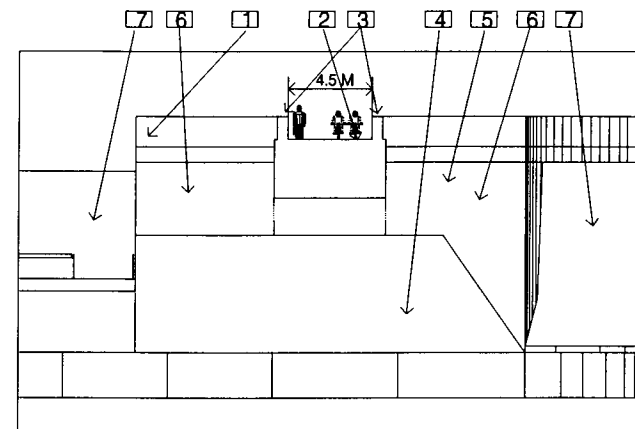

SECTION LOOKING WEST

POOLEY'S BRIDGE REHABILITATION ALT. 4A

FIG 10

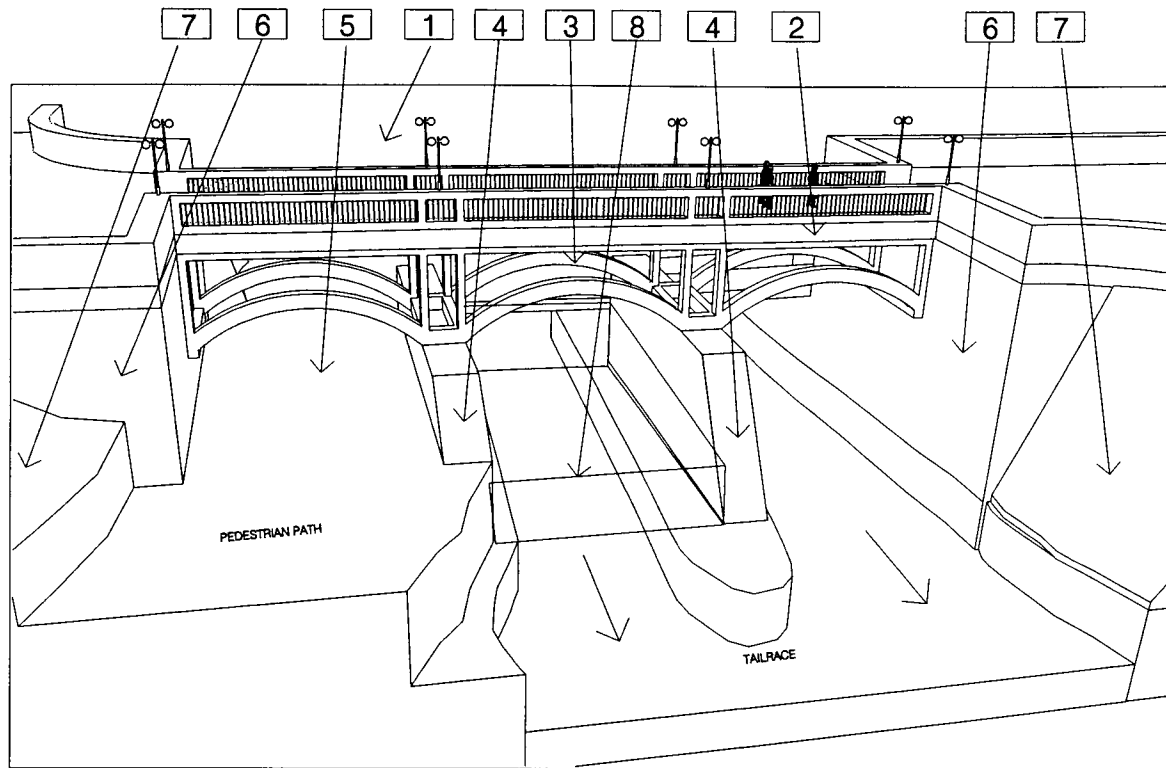

PERSPECTIVE VIEW FROM NORTH

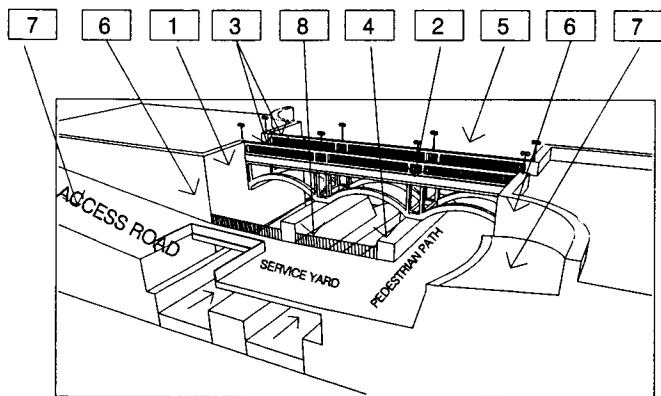

PERSPECTIVE VIEW FROM SOUTH

Drawing Legend:

1. Remove existing south stone spandrel wall between abutments. Restore the rest of the wall.
2. New pedestrian bridge structure (precast/concrete/steel).
3. Precast concrete and/or steel railing.
4. Retain and stabilize existing stone piers as "ruins".
5. Remove deteriorated portion of bridge.
6. Retain and stabilize east and west abutments on both sides of new pedestrian bridge.
7. Landscaping to remain.
8. Remove existing timber cribwork.

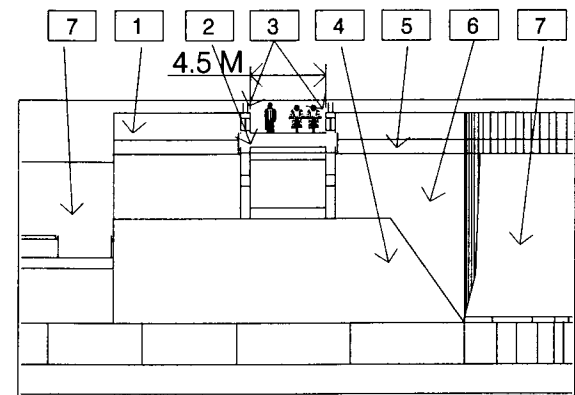

SECTION LOOKING WEST

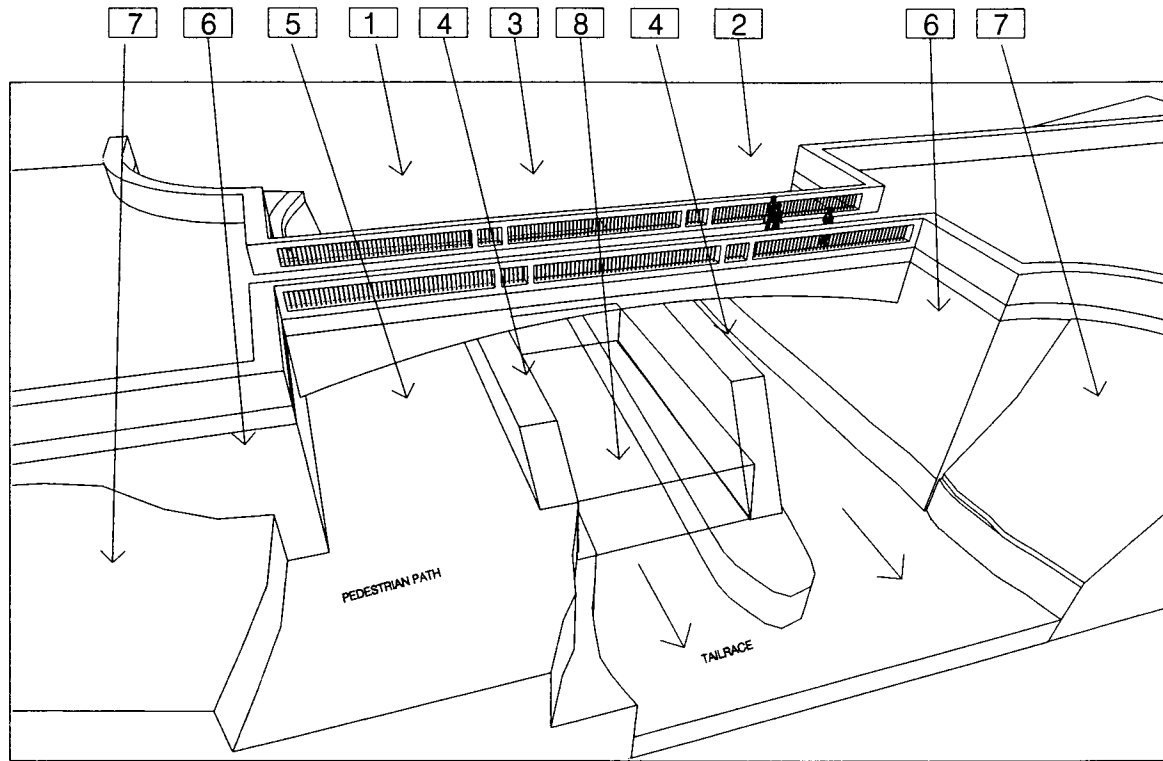

PERSPECTIVE VIEW FROM NORTH

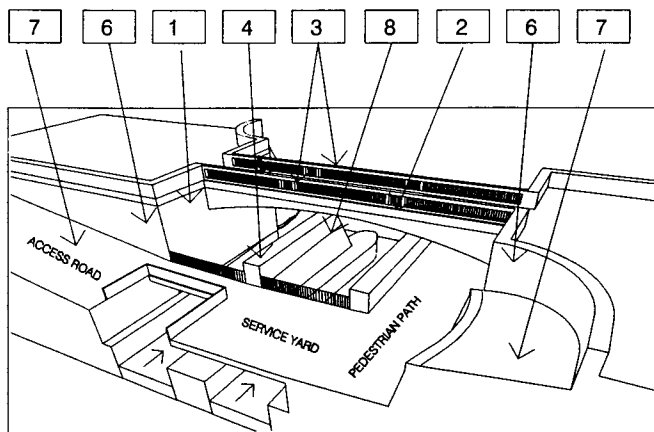

PERSPECTIVE VIEW FROM SOUTH

Drawing Legend:

1. Remove existing south stone spandrel wall between abutments. Restore the rest of the wall.
2. New pedestrian bridge structure (precast/concrete/steel).
3. Precast concrete and/or steel railing.
4. Retain and stabilize existing stone piers as "ruins".
5. Remove deteriorated portion of bridge.
6. Retain and stabilize east and west abutments on both sides of new pedestrian bridge.
7. Landscaping to remain.
8. Remove existing timber cribwork.

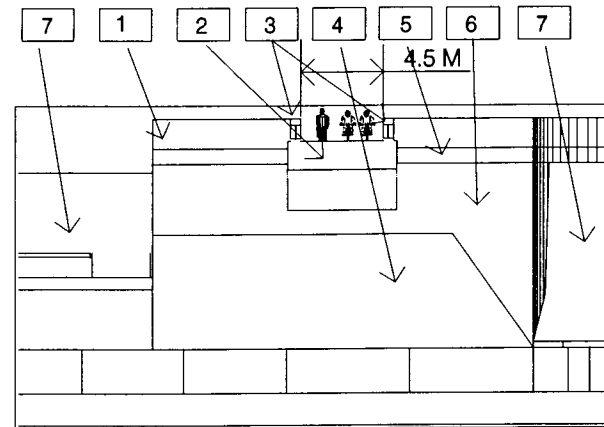

SECTION LOOKING WEST

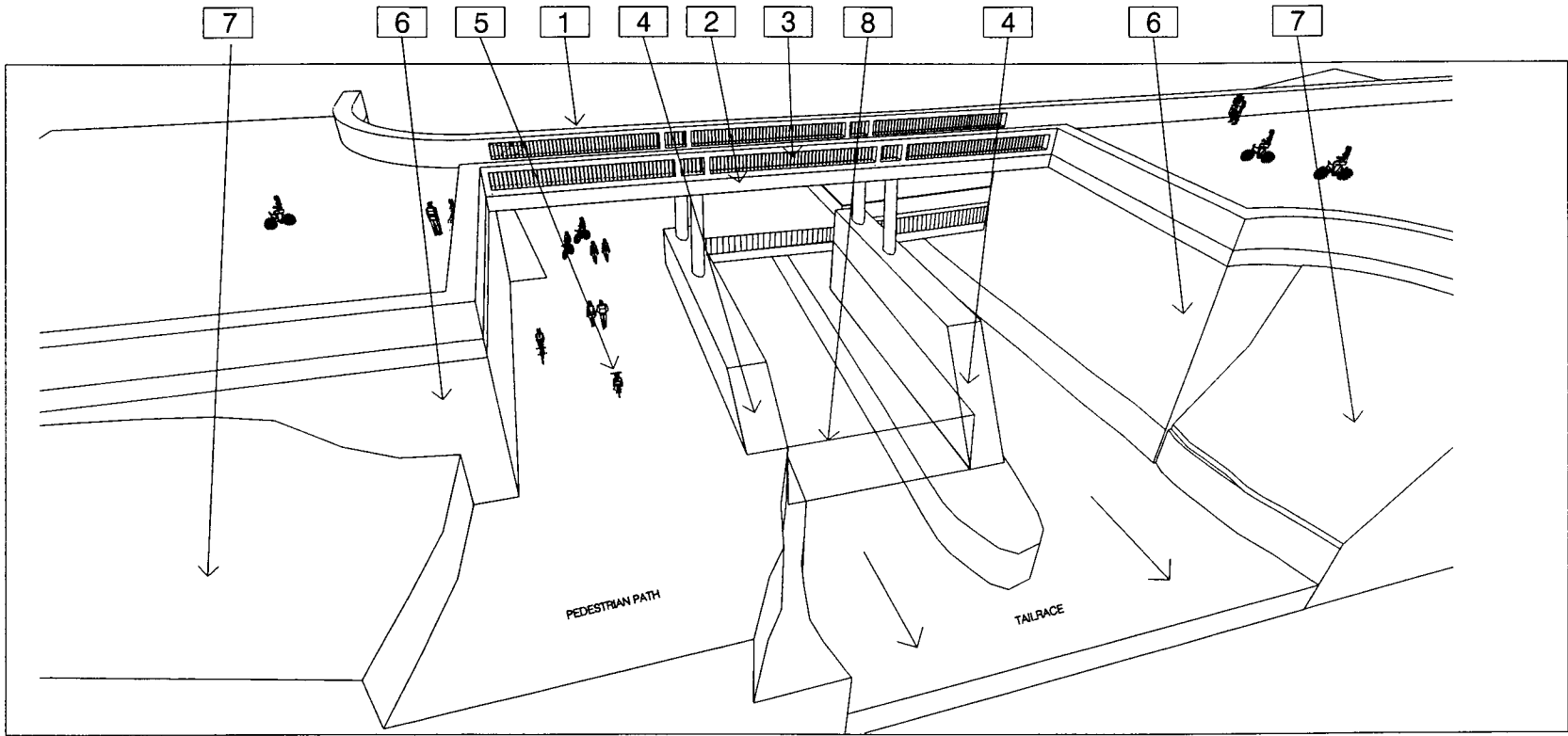

PERSPECTIVE VIEW FROM NORTH

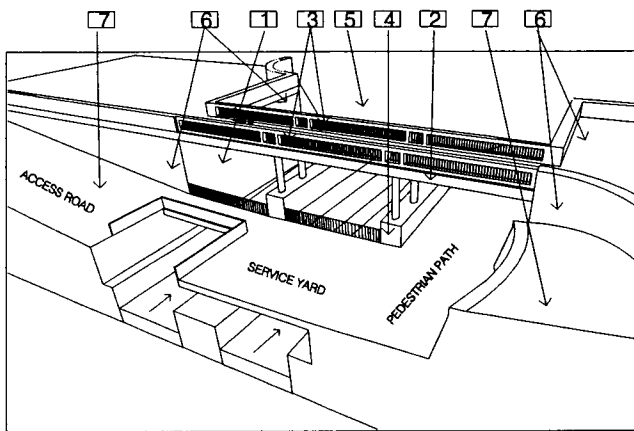

PERSPECTIVE VIEW FROM SOUTH

Drawing Legend:

1. Remove existing south stone spandrel wall between embankments. Restore the rest of the wall.
2. New pedestrian bridge structure (steel).
3. Steel railings.
4. Retain and stabilize existing stone piers as "ruins".
5. Remove deteriorated portion of bridge.
6. Retain and stabilize east and west abutments north of new pedestrian bridge.
7. Landscaping to remain.
8. Remove existing timber cribwork.

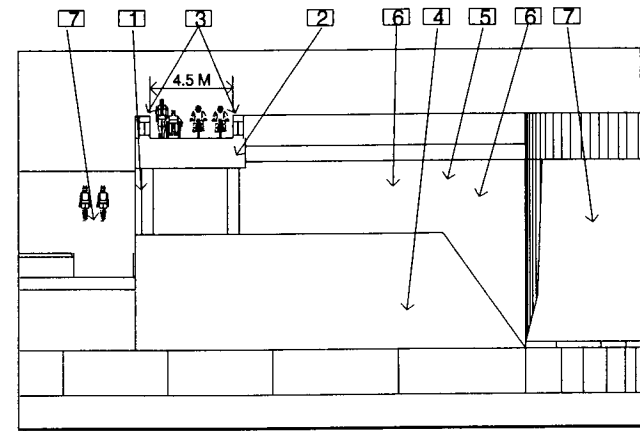

SECTION LOOKING WEST

**POOLEY'S BRIDGE REHABILITATION ALT. 5A**

**FIG 13**

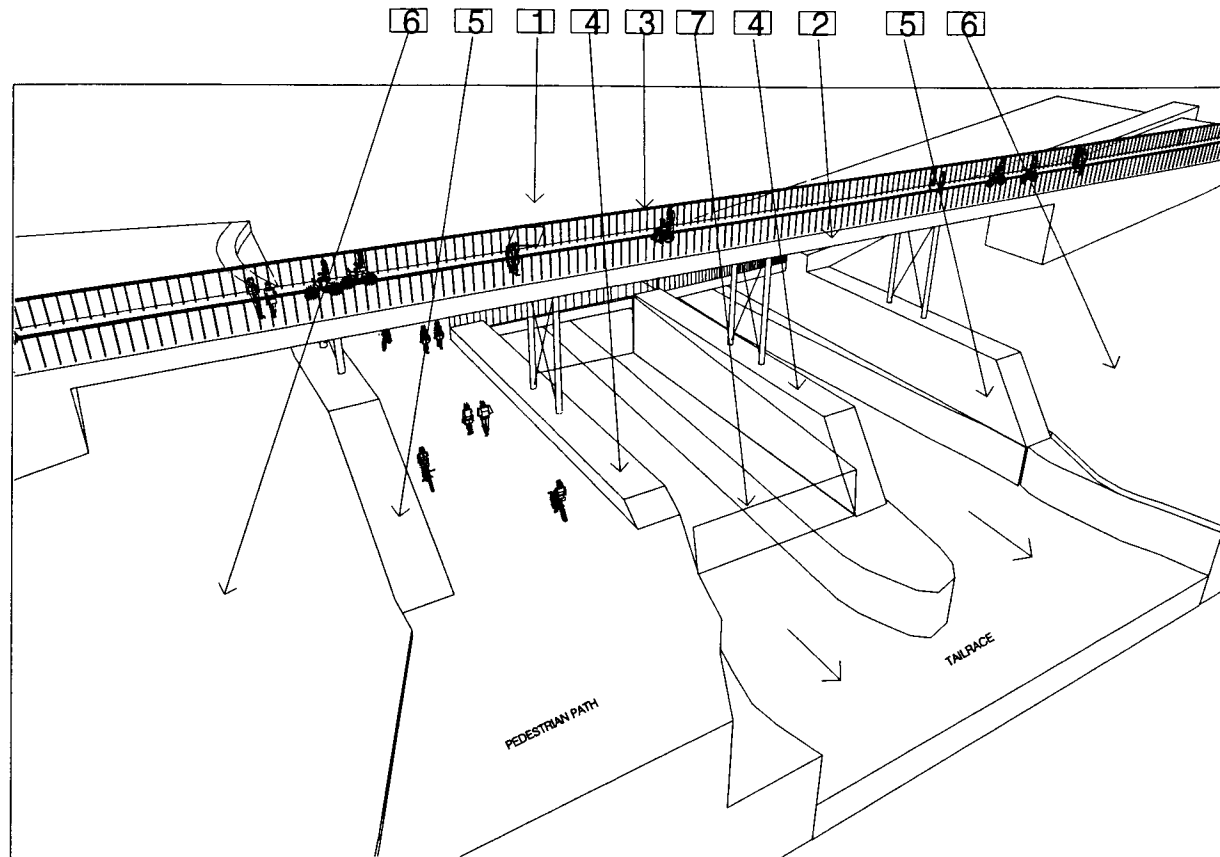

PERSPECTIVE VIEW FROM NORTH

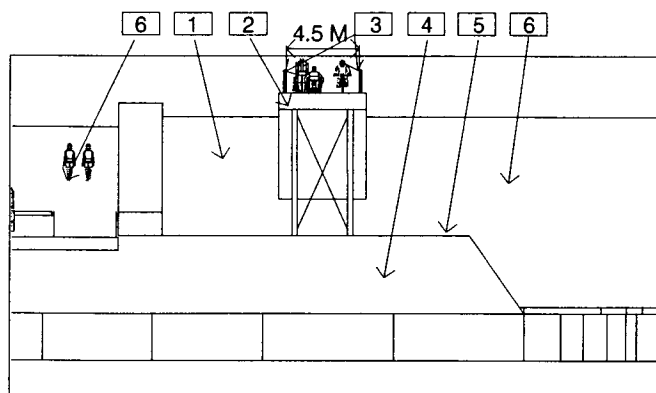

SECTION LOOKING WEST

Drawing Legend:

1. Remove existing bridge.
2. New pedestrian bridge structure (steel).
3. Steel railings.
4. Lower and stabilize existing stone piers.
5. Lower and stabilize east and west abutments.
6. Re-grade and new landscaping for abutment replacement.
7. Remove existing timber cribwork.

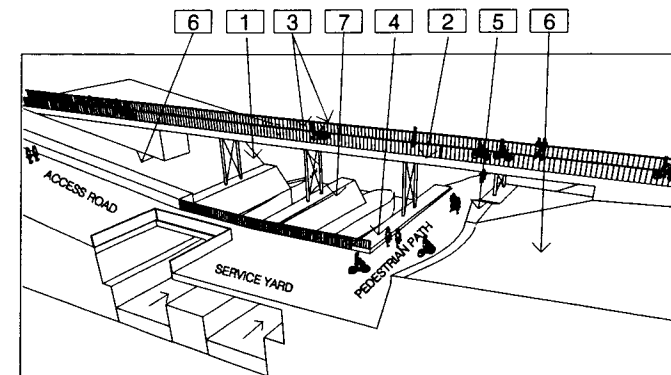

PERSPECTIVE VIEW FROM SOUTH

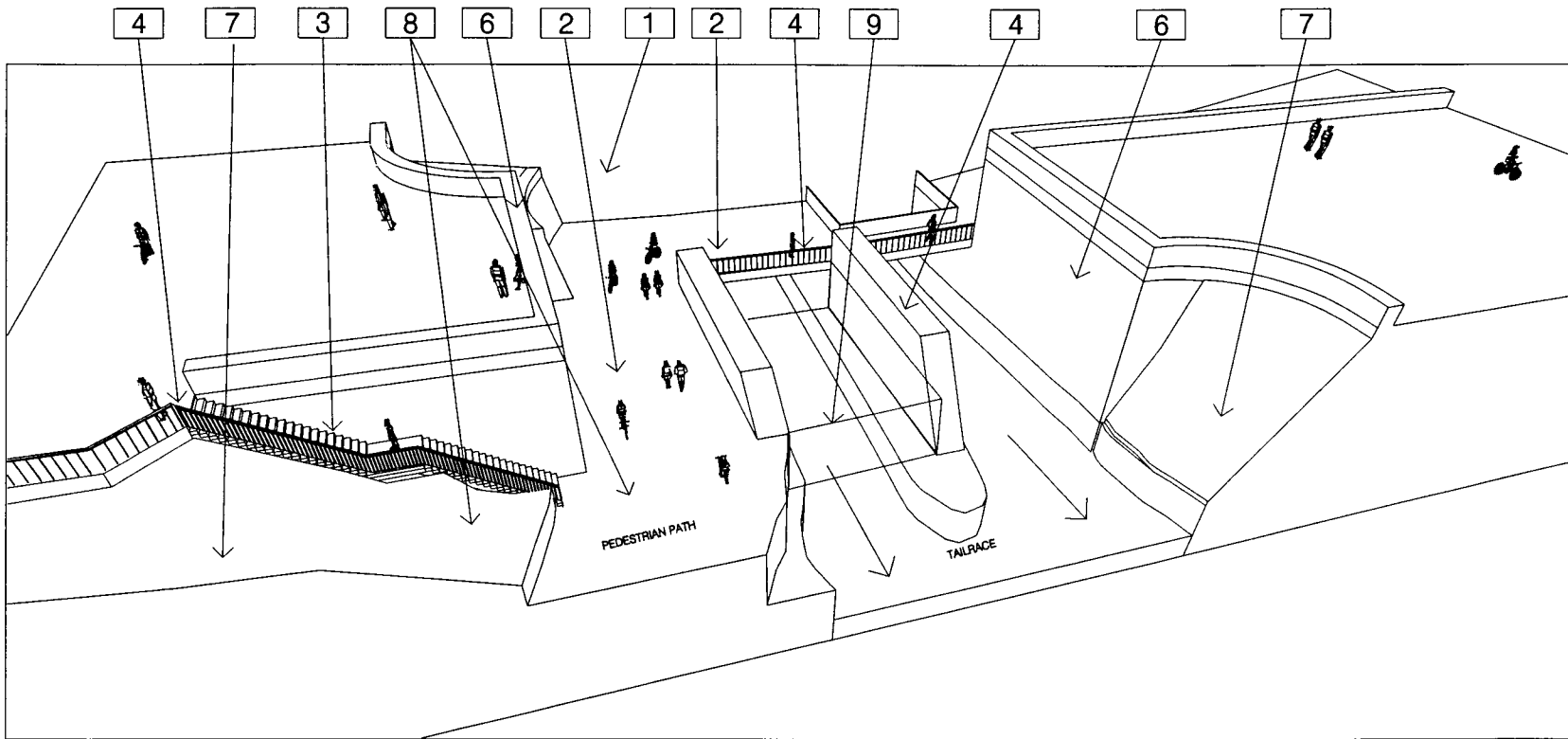

PERSPECTIVE VIEW FROM NORTH

Drawing Legend:

1. Remove existing bridge.
2. Existing pedestrian path.
3. New stairs.
4. Steel railings.
5. Retain and stabilize existing stone piers as "ruins".
6. Retain and stabilize east and west abutments.
7. Landscaping to remain.
8. New regrading and landscaping for pedestrian path and stair.
9. Remove existing timber cribwork.

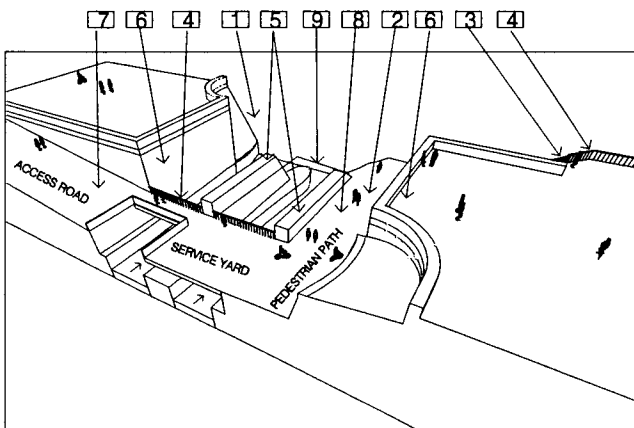

PERSPECTIVE VIEW FROM SOUTH

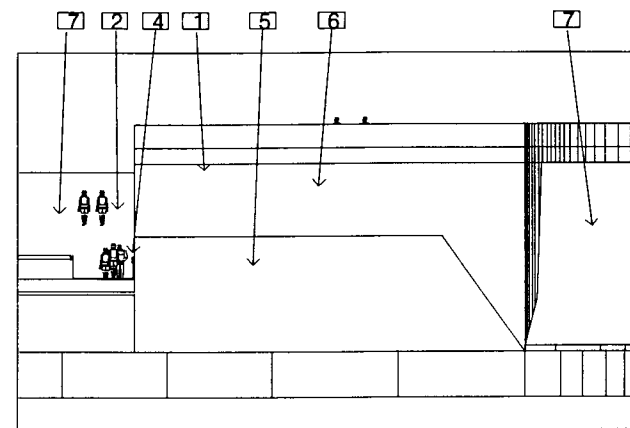

SECTION LOOKING WEST

**POOLEY'S BRIDGE REHABILITATION ALT. 6**

**FIG 15**